



# ANDERSON

INNOVATIONS

## User Manual

# ES 1300 Ride On Floor Scraper

---

US Patent # 10273700, 10619365

EU Patent # EP3642429



**READ BEFORE USING EQUIPMENT**

Anderson Innovations

5506 Thompson Hill RD

Duluth, MN 55810

[www.andinllc.com](http://www.andinllc.com)





# TABLE OF CONTENTS

<b><u>1</u></b>	<b><u>Safety</u></b>		
		1.1	Manual 4
		1.2	Explanations of symbols and instructions 4
		1.3	Intended use 5
		1.4	Owner's obligations 5
		1.5	Operating personnel 6
		1.6	Personal protective equipment 7
		1.7	Signage 7
		1.8	Safety installations 7
		1.9	Occupational safety and special risks 8-11
<b><u>2</u></b>	<b><u>Product Information</u></b>		
		2.1	Technical Description 12
		2.2	Technical Specifications 12
		2.3	Scope of delivery 12
		2.4	Controls and equipment 13
<b><u>3</u></b>	<b><u>Transport</u></b>		
		3.1	Lifting With a Forklift 14
		3.2	Using a Ramp 14
<b><u>4</u></b>	<b><u>Setup</u></b>		
		4.1	Blade Choice 15
		4.2	Blade Angle 16
		4.3	Weights 16
		4.4	Weights 17
<b><u>5</u></b>	<b><u>Operation</u></b>		
		5.1	Start-up / Shut-down 18
		5.2	Safe Operation 18
		5.3	Removal of floor coverings 19
		5.4	Battery System 20
<b><u>6</u></b>	<b><u>Maintenance</u></b>		
		6.1	Sharpen blades 20
		6.2	Regular maintenance 21
		6.3	Hydraulic oil 22 - 23
<b><u>7</u></b>	<b><u>Attachments</u></b>		
		7.1	LNEX Battery Monitor / S.O.C. Manual 26-32
		7.2	Lithium Battery Guide 33-38
		7.3	Dakota Lithium Battery SDS 39-44
		7.4	Hydraulic Oil SDS 45-60
		7.5	Manufacturer Information 61

# 1 SAFETY

## 1.1 Manual

This manual guarantees the safe and efficient use of the ES 1300 "machine". This manual is part of the machine and must always be kept near the machine and be accessible for the operating personnel at all times.

The operating personnel have to have carefully read and understood this manual before any work begins. Prerequisite for safe working is compliance with all the safety and handling instructions in this manual.

Furthermore, this machine is to be used in compliance with all local regulations and the general safety requirements set forth by the Occupational Safety and Health Administration.

Illustrations in this manual are for the purpose of explanation and may differ from the actual design of the machine.

When passing the machine on to third parties this manual must be included.

All of the instructions and technical specifications in this manual have been written in compliance with current technical norms and regulations together with our many years of knowledge and experience.

In the following cases the manufacturer does not accept any liability:

- Non-compliance with these instructions
- Improper use
- Operation by untrained personnel
- Unauthorized modifications
- Technical modifications
- Use of unauthorized replacement parts

## 1.2 Explanations of symbols and instructions

Safety instructions in this manual are marked by symbols. Instructions are introduced by signal words which express the scale of the hazard.

It is essential that these instructions are adhered to and the machine is operated with caution to avoid accidents, injuries and material damage.



### **WARNING!**

Indicates a potentially dangerous situation which if not avoided can lead to death or serious injuries.



### **CAUTION!**

Indicates a potentially dangerous situation which if not avoided can lead to minor or light injuries.



### **PROHIBITION!**

Indicates an immediate dangerous situation which if not avoided can lead to death or serious injuries.



### **Safe Practices**

Emphasizes tips and recommendations as well as information for efficient and failure-free operation.

# 1 SAFETY

## 1.3 Intended use

The machine is used for the removal of all sorts of floor-coverings for example PVC, linoleum, carpets, rubber floors as well as tiles, coatings, adhesives and wood flooring.

The machine is NOT to be used to pull things or for non flooring related demolition work.



Any use beyond the intended use or other types of use is considered misuse.

### **WARNING! Danger due to misuse!**

Misuse can lead to dangerous situations.

- Operation outside the specified limit values of the technical data.
- Bypassing or overriding of safety installations.
- Remodeling, refitting or changing the construction or individual parts with the intention to alter the area of application or use of the machine.
- Use of the machine when not in perfect mechanical condition.
- Use of the machine in potentially explosive areas.

## 1.4 Owner's obligations

### **Claims of any sort of damages following improper use:**

The owner is a person who operates the machine for personal, commercial or economic use or leaves it to a third person for use/application and during its use carries the legal responsibility for the protection of the user, personnel or a third person. The machine is used in the commercial sector. The owner of the machine is therefore obliged to comply with the legal responsibilities for health and safety.

The local regulations of the place of use as well as accident prevention measures of the local trade association must be adhered to.

It applies in particular that the owner:

- is informed about current health and safety regulations.
- determines during a risk assessment additional hazards which occur through specific working conditions on the operating site of the machine.
- implements in a job control statement the necessary compliance requirements for the operation of the machine on the operating site.
- regularly examines during the entire operating time that the operating instructions comply with the current status of regulations.
- that the operating instructions-if necessary- are adjusted to new regulations, standards and conditions of use.
- clearly regulates the responsibilities for the installation, operation, maintenance and cleaning of the machine.
- ensures that all staff working near or with the machine have read and understood the operating instructions. Furthermore the owner will train all personnel as needed to adequately inform them about possible hazards.

Additionally the owner is responsible for:

- safe operating condition of the machine.
- the servicing of the machine in the recommended maintenance intervals.
- the regular inspection of all safety installations ensuring that they are complete and in working order.

# 1 SAFETY

## **1.5** **Operating** **personnel**

### **QUALIFICATION**

The different tasks described in this manual request various qualifications from the persons dealing with the machine.



### **WARNING! Danger for persons with insufficient qualifications!**

Insufficiently qualified persons can not judge the risks when operating the machine and put themselves and others at risk of serious injuries or death.

- All work must only be performed by qualified personnel.
- Insufficiently qualified persons must be kept away from the operating area.

In this manual the necessary qualifications for the persons and the different tasks are listed:

#### **OPERATOR:**

the operator has been instructed by the owner and been given the assigned tasks and has been informed about the possible hazards in case of improper behavior. Tasks which go beyond regular operation tasks can only be executed by the operator if listed in this manual and have been explicitly authorized by the owner.

#### **TRAINED PERSONS**

have been instructed by the owner and been given the assigned tasks and have been informed about the possible hazards in case of improper behavior.

#### **QUALIFIED PERSONNEL**

Qualified personnel is able to carry out assigned tasks and recognize and avoid independently possible hazards given their specialist training, knowledge and experience as well as their knowledge of relevant norms and regulations.

#### **MANUFACTURER**

Certain work can only be carried out by trained personnel of the manufacturer. Other personnel are not authorized to carry out this work. Please contact customer service for required work.

#### **UNAUTHORIZED PERSONS**

**WARNING! Danger for unauthorized persons in the operating area!**

- Unauthorized persons have to be kept away from the operating area.
- If in doubt remove persons from the operating area.
- Interrupt the work as long as unauthorized persons are in the operating area.

### **INSTRUCTION**

The owner of the machine must regularly instruct all personnel. For better documentation an instruction protocol with the following minimum content has to be kept:

- date, content of the instruction
- name of the instructor
- signatures of the instructed and instructor

# 1 SAFETY

## 1.6 Personal protective equipment

When operating the machine personal protective equipment must be worn in order to minimize health hazards.

The following protective clothing must be worn by anybody in the operating area.



Protective work clothing.

Wear appropriate work clothing! Work clothing should fit tightly and loose garments should be avoided since they can get caught in the machine.



Protective gloves

Protective gloves to protect your hands when changing blades.



Ear protection + Protective goggles

Ear protection offers you protection from hearing damage through noise. Protective goggles protect your eyes from flying debris.



Safety shoes

Safety shoes protect your feet from bruising and from sharp objects and from slipping on slippery ground.



Respirator mask

Regular and prolonged exposure to dust can lead to chronic and debilitating lung disorders. When working for a long time or on dusty ground a minimum of a NIOSH N95 dust mask has to be worn to protect your respiratory tract from dust and from small particles.

## 1.7 Signage



**WARNING! Danger with illegible signage!**

With time labels and signage can become dirty or illegible so that hazards can not be recognized and necessary instructions adhered to. This causes an increased risk of injury.

- Keep all safety, warning and operating instructions always in legible condition.
- Damaged labels or signage must be replaced immediately.

The following symbols and signs can be found in the operating area. They refer to the immediate area where they have been placed.

### WARNINGS

sharp blade,

Sharp Object / Wear



Pinch Point



Danger to hands



Electrical Hazard



## 1.8 Safety installations



**WARNING! Danger through defective safety installations!**

Defective or disabled safety installations can cause severe injuries and death.

- Before work can start all safety installations have to be inspected to see whether they are functioning properly and have been correctly installed.
- Never disable safety methods or override them.
- Make sure that all safety methods are always accessible.

# 1 SAFETY

## 1.9

### Occupational safety and special risks

The following paragraph explains residual risks which might be present even if the machine is used correctly.

To reduce the risk for persons and material damages and to avoid dangerous situations the listed safety information in this paragraph and in the remaining manual has to be adhered to.

#### Improper use



#### **WARNING! Danger through improper use!**

##### **Make sure:**

- Only use machine when in good operating condition.  
Broken parts must be repaired or replaced immediately.
- Modifications to the machine are not permitted and can impair safety.
- Before regular maintenance, cleaning and repairs the power must be switched off and secured against unintentional start-up.
- Never override, remove or switch off safety devices.
- All work on the machine and/or its electrical components must be carried out by trained personnel.
- Repair or maintenance work must only be carried out when the machine is switched off.  
The machine must be secured against unintentional start-up.

#### Axis movements



#### **WARNING! Danger of struck by injury!**

Collision of persons with the machine or its tools can lead to severe injury.

##### **Make sure:**

- Unauthorized persons in the operating area are strictly prohibited!
- Safety installations and/or functions must not be switched off or overridden.
- Do not hold any body parts between moving components.
- Blades must only be changed when the machine is idle, secure, and disconnected from power.
- Wear personal protective equipment in the operating area.
- Assistants must always keep a safety distance of a minimum radius of 3 feet from the machine.

#### Removed materials



#### **WARNING! Injuries through removed materials!**

The removed floor-covering can fracture causing debris to fly around or be thrown around unexpectedly and cause serious injury or damage to the surrounding area

##### **Make sure:**

- Wear face protection or fully closed and tight fitting goggles, protective clothing, protective gloves and safety shoes.
- Seek medical attention immediately if particles have entered your eyes.
- Assistants must always keep a safety distance of a minimum radius of 3 feet from the machine.
- Use protective coverings on delicate surfaces near the work area

# 1 SAFETY

## 1.9 Occupational safety and special risks



### Sharp edges and sharp corners

**CAUTION! Danger of injury from sharp edges and sharp corners!**  
Sharp edges and sharp corners can scratch and cut into your skin.

Make sure:

- Be careful when working near sharp edges and sharp corners.
- Wear protective gloves when in doubt.



### Cutting tools (knives/blades)

**CAUTION! Danger of injury through improper use of tools!** Scraping blades and associated tooling can cause severe injuries if handled improperly. Always wear protective clothing. Make sure blades are securely mounted when transporting, during maintenance and when in use. When installing blades never push a wrench toward the cutting edge.

- Use tools carefully and as intended.
- Consider the weight of tools in transport.
- Wear protective gloves and safety shoes.



### Working environment

**CAUTION! Avoid dangerous conditions!**

Do not operate machine in rain, extreme humidity, wet areas or in explosive environments (gaseous vapors, dust or flammable materials). Remove materials and debris which can be ignited by sparks.

Keep your working area clean and well lit.  
Untidy and dark working areas increase the danger of accidents.

Keep spectators away from the working area.  
Children and spectators must keep a safe distance from the working area to keep from distracting the operator and not come in contact with the machine. The operator must always be aware of who is nearby.

Protect other persons in the working area.  
Provide safety screens and protective shields to protect others from the movement of the machine and debris.

Always be aware of the position of your coworkers when the machine is in operation. Close off working area from unnecessary foot traffic.  
Personnel in proximity must never be in front or behind the running machine. Non-compliance can lead to serious injuries or death.

Keep working area clean! Unsecured, scattered components and tools are a potential source for accidents

# 1 SAFETY

---

## 1.9

### Occupational safety and special risks



#### Start-up and operation

**WARNING! Danger of injury through improper start-up and operation** Improper start-up and operation can lead to personal injury or material damage.

Make sure:

- Start-up and operation can only be executed by sufficiently trained personnel, authorized and instructed by the owner of the machine.
- Before work commences all safety installations have to be inspected to check whether they are functioning properly and have been correctly installed.
- Keep working area tidy and clean! Unsecured, scattered components and tools are a potential source for accidents

**WARNING! Non-stop work; Incorrect handle height, vibrations and machine movements cause pain and fatigue**

Make sure:

- Take regular breaks

#### Maintenance and troubleshooting



**WARNING! Danger of injury through improper maintenance and troubleshooting!** Improper maintenance and troubleshooting can lead to severe personal injury and material damage.

Make sure:

- Any maintenance work and troubleshooting must only be carried out by sufficiently qualified and instructed personnel.
- Secure machine from unintentional start-up.
- Provide sufficient space before starting maintenance work.
- Keep working area clean and tidy! Unsecured, scattered components and tools are a potential source for accidents.

When components need to be replaced:

- Contact manufacturer or authorized representative.



# 1 SAFETY

## 1.9 Occupational safety and special risks



### ELECTRICAL CONNECTIONS / Charging /ELECTRICAL COMPONENTS

#### **WARNING! Risk of death due to electric current!**

Only connect the machine / charger to a power source that matches the the rating plate. Check before startup.

Only connect the machine to an approved power cable and outlet. Cables / extention cords must be at least 12AWG with molded plugs having ground lugs not exceeding 25ft. Using the machine with cables of insufficient gauge and / or excessive length may result in poor performance, overload, tripped breakers and personal injury or property damage.

Have electrical equipment such as breakers, power cord, extension cables checked by an authorized electrician. If the circuit breaker trips or trips repeatedly, it is a sign of a problem. Never use equipment on unprotected circuits.

Never work with a damaged cable or plug. Worn or damaged cables or plugs should be replaced by an electrician or authorized service personnel.

Do not use damaged electrical cords. Do not pull on the cable to unplug from the wall. Using the machine charger with a damaged cable can cause an electric shock.

Never remove or make unusable a ground lug from machine or cords. Using the machine in a non-grounded circuit may result in electrocution. Consult an electrician if the grounding wire is missing or if you believe that the circuit does not have adequate grounding.



The machine may only be operated on circuits with current protective device (I.E. fuse or circuit breaker).

When working on the machine always unplug the battery!  
Maintenance, replacement or adjustment of components may result in personal injury to the operator and / or bystanders when the machine is started accidentally.

Work on electrical components of the machine may only be carried out by a qualified electrician.

Driving over or damaging the power cables with the machine may result in electric shock.

The machine is only suitable for operating in dry conditions. Do not expose the machine to water including Rain, pressure washers, hoses.

## 2 PRODUCT INFORMATION

### 2.1 Technical Description

#### **SPECIAL FEATURES**

A powerful motor combined with a highly efficient hydraulic drive system produces excellent performance at an extremely low noise level.

The ES 1300 is a compact yet powerful ride-on floor scraper. It is capable of removing difficult flooring such as ceramic, wood, tough carpet and epoxy coating. The high performance lithium battery provides up to 4000 cycles and can be changed out when depleted for a fully charged battery providing the

### 2.2 Technical Specifications

#### Technical Data

Power Supply	48 VDC
Drive System	Hydraulic
Motor Size	5 HP
Speed	Up To 140 ft/min
Total Weight	1300 lbs Removable Weight 325.5 lbs
Length	52"
Width	24"
Height	38.5"

U.S. Patent # 10273700, 10619365  
E.U. Patent Granted



### 2.3 Scope of delivery

- Machine with 1 - 48V - 96AH Lithium Battery
- 6" Blade Holder
- 12" Blade Holder
- 2" Carbide
- Safety Glasses and Cut resistant gloves
- Battery Charger
- Retaining Pins
- Safety Manual
- Blade and Slide Plate Adjustment Wrench

## 2

# PRODUCT INFORMATION

### 2.4 Controls and equipment

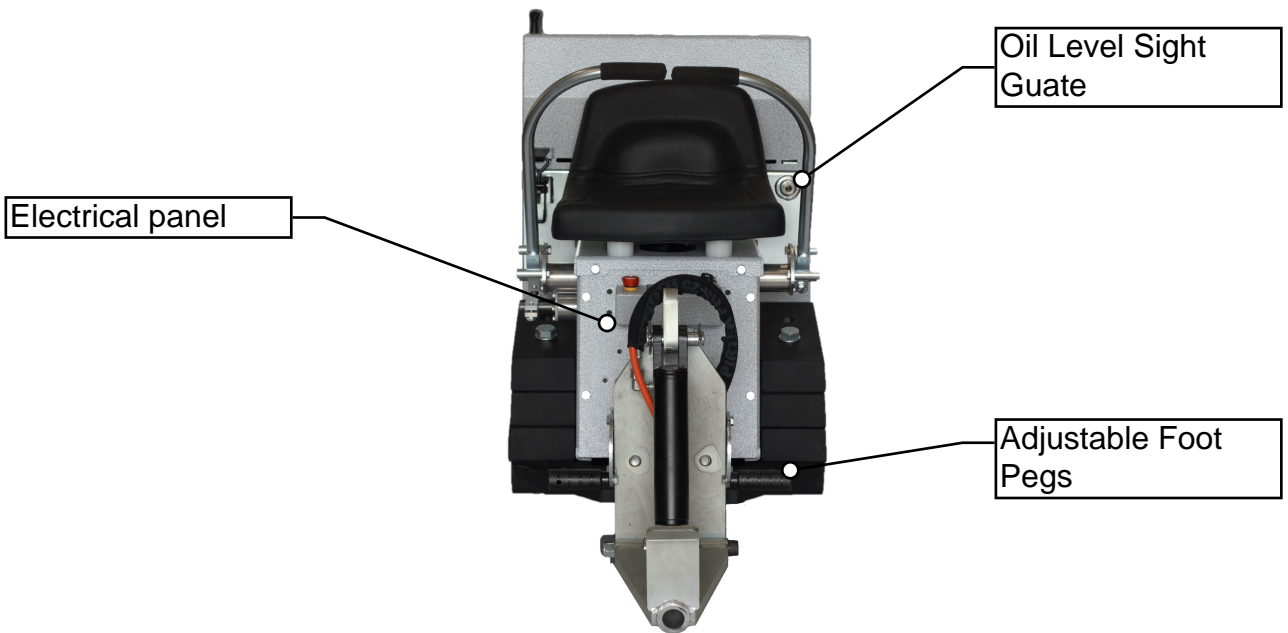
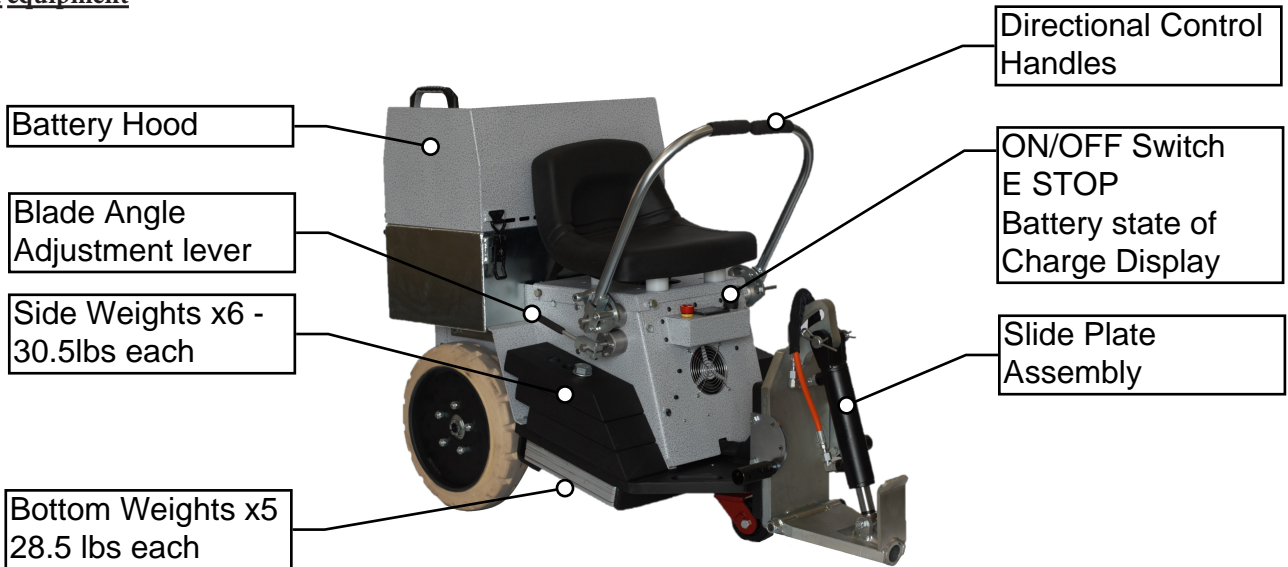

## 3 TRANSPORT

### 3.1 Lifting

Before using lift-gates, elevators or other powered lifting tools make sure the lift equipment is in good operating condition and is properly sized for use with this machine. Refer to product specifications in this manual for weight and dimensions.

The machine can be moved without power by opening the hydraulic valves in the intended direction of travel and then pushing the machine. **DO NOT** push the machine with full weight applied to the control handles. Pushing or pulling the machine by the control handles will cause damage to the handles and control linkages.

#### **FORKLIFT:**

Placing the machine on a skid is the safest way to lift with a forklift. If using a forklift to move the machine without a skid / pallet, special attention must be given to fork placement.

1. Set the forks to the inside width of the tires
2. Pickup the machine from the back getting as close as possible to the mast of the lift truck
3. Ensure the forks are completely under the weight tray and not catching on the front caster
4. Slowly lift the machine and tip the mast back



### 3.2 Ramps

#### USING RAMPS:

Extra care must be taken to ensure the safe use of a ramp. The ramp **MUST** be rated for the weight of the machine and the operator. The operator is responsible for adhering to any safety regulations that apply in their area of work.

OSHA regulation 29 CFR 1926.451(e)(5)(ii)

No ramp or walkway shall be inclined more than a slope of one (1) vertical to three (3) horizontal (20 degrees above the horizontal).

- Ramps can be dangerous to use
- Make sure ramp is rated to hold machine and operator
- Ramp must be secured so it cannot slip off on the high side
- Be sure ramp is free of debris and is not slippery
- ALWAYS back up a ramp, keeping the front of the machine "down hill"
- ALWAYS drive down a ramp keeping the front of the machine "down hill"

## 4 SETUP

### 4.1 Blade Choice of blade

Using the correct blade size and style for various floor coverings and sub-floors will provide the best performance of your machine.

The principles described are to help operators choose the best type of blade for each job. There is not a "one size fits all" option with blade choice.

#### **Blade size**

For harder jobs it is better to use narrow blades, for easy jobs you can select wider blades.

Narrow blades can increase production on tough jobs as the machine will have less resistance and faster travel speed compared to using a wider blade and will allow for longer run time and a cleaner subfloor. Start with a narrow blade, switch to a wider blade if the material is coming up easily.

#### **Blade bevel**

Bevel up blade is for hard substrate like concrete.



Bevel down for wood or soft sub-floors.



#### **Self-scoring blades**

When using self-scoring blades for soft floors, pre-scoring the flooring material is unnecessary. Depending on the type of flooring to be removed and the sharpness of the blade, it will be more difficult to control the machine.

Keep the blade and the side wings/edges sharp.

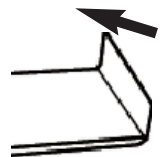

#### **Insert / replace blade**

Dull blades reduce the capacity and cutting performance of the machine. Sharpen or replace the blades as needed.

#### **Remove the power plug**

**CAUTION ! Even "dull blades" can cut you.** Wear protective gloves



Use supplied extended wrench to keep hand safely away from the edge of the blade. When installing or removing blade **NEVER** use a short wrench that puts hand in-line with the blade or push toward the cutting edge.



# 4 SETUP

4.2 FZWE#%" ZSe\$ T'SW\$Vgef\_ WfezA` WadfZVZVZf aXZV[WV  
 b'SfVSeW T'kaXaXZVWaadS` VS eMa` VXdZV\$ YVaxZW  
 T'SWZ` YWWSIS'ai fa\_ Wlg\_ S` YW [^i ad TWfXd  
 dW ah` Y\_ SFW\$'eegUZSeYgWVai ` USbW H5F and UWS\_ [U  
 f[VWA h[YZS` YWeTWfWeg[fWXdMUSb]` YSVZWhVS` V  
 dW ah` YfZ[` UaSf` YeZFWi a` SdWta'fea` fZMSU] aXZV[WV  
 b'SfVSeW T'kZaVfZV[Wb'SfVsf fZVWdWZVZfZGeVZW  
 %\_ \_ eaU W/a` fZW UgWwi dWUZfa`aaeW fZVta'feS` VfZW  
 dSleVad'ai WfZV[Wb'SfVSe WdWZfb[LS`k [f[eTWf fa geVS  
 Z[YZ e[VWb'SfVWadsZ]YZ T'SW\$` YV\$` VS`ai e[VWb'SfVWads`ai  
 T'SW\$` YVfZVIT'SW\$` YWeSVgefWi [fZfZWa` fch^Wta` fZW  
 `ai dYZfZS` Ve[VWaxZW SUZ]` W



>ai 4'SW3` YW

? Wlg\_ 4'SW3` YW

: [YZ 4'SW3` YW

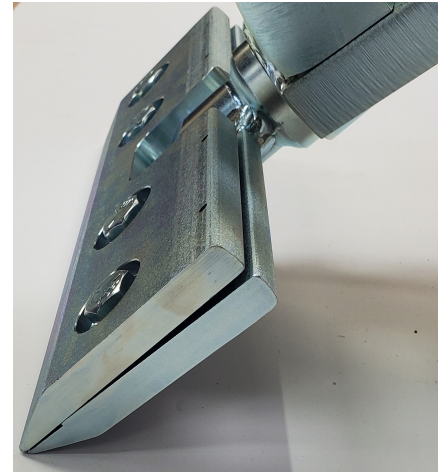
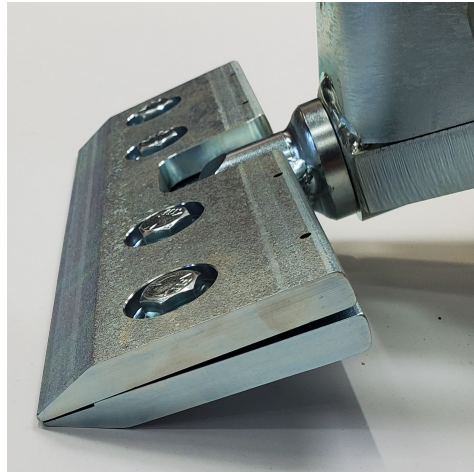
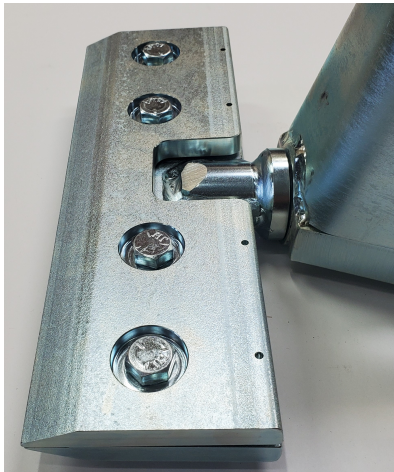

I ZWUZaad` YST'SWt [eTWf fa\_ SFUZ fZV] VaxZW'SWw fZVZa`W3` SdWIT'SWVWVW]` YbSef fZW  
 e[VWaxZWa`Wti [^TWinsupported S` Vless effective at cleaning the floor. A small blade in a large holder  
 can allow material to catch on the edges of the holder. For the best performance and efficiency match the size  
 of the blade with the holder

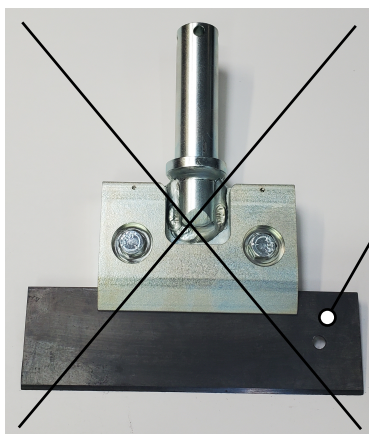

This blade is too big for the holder

These blades are matched to the size of the holder

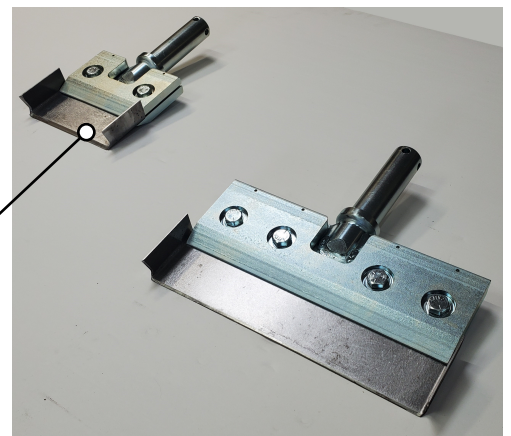

## 4 SETUP

### 4.3 Weights



Use caution when handling weights. It is possible to pinch or crush fingers as well as drop heavy parts onto your feet. Wear gloves and safety shoes to help protect from injury.

#### Removing Weights

Depending on your application it may be necessary to remove weight from the machine. Some common reasons to remove weight include: weight restriction for elevator or lift gate, soft sub-floor that requires less pressure on the cutting edge, restricted point load for elevated working surfaces. You will need a couple of tools to remove the weights on the ES1300. Including a 36mm socket or wrench, 3/4" socket or wrench and possibly a soft hammer or mallet.

Removing the side weights:

1. Use a 36mm wrench or socket to remove the weight bolt. This bolt threads into a pin that holds the weights in place. The weights will not slide off the machine after the bolt is removed
2. Lift the weights off the pin and set them aside
3. Re-install the weight bolt so that it does not get misplaced

Installing the side weights:

1. Remove the weight bolt if installed
2. Line up the corresponding mounting hole in the weight and set onto the pin. The front of the weights should line up as shown in the image.
3. Re-install the weight bolt

Removing the bottom weights:

1. Use a 17mm socket or wrench to remove both bolts as shown from the bottom of the machine
2. Use a soft hammer or mallet if necessary to move the top weight in the stack out of the machine.
3. Repeat for each additional weight.
4. Install the weight bolts when finished to keep them from being misplaced

Installing the bottom weights:

1. Remove the weight bolt if necessary
2. Install the weight plates. **WARNING** fingers can be pinched between the handle of the weight and the machine or other installed weights
3. line up the weight stack so it is flush with tray on both sides, use a soft hammer or mallet if necessary
4. Install the weight bolts

Weight Bolt

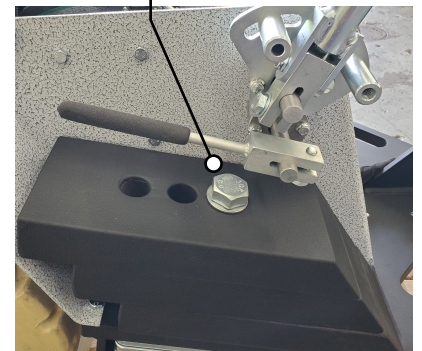

Bottom Weights



## 5 OPERATION

### 5.1

#### Start-up and Shut Down

To start the machine follow this procedure:

1. Inspect the machine for any signs of hydraulic leaks for other damage
2. Spread the handles apart and sit on the seat with feet on the foot pegs
3. With the handles in the center/neutral position twist the red cap on the E-Stop to make sure it is in the "up" position
4. Turn the key switch fully to start the machine.

To shut down the machine follow this procedure:

1. Allow the control handles to return to the center / neutral position
2. Make sure the machine is on a flat, level surface. Do not park the machine on a ramp or inclined surface.
3. Use the blade angle adjustment to lower the blade so the cutting edge is on the floor.
4. Turn the key switch to the off position
5. Remain in the seat until the motor has completely stopped
6. Step off of the machine

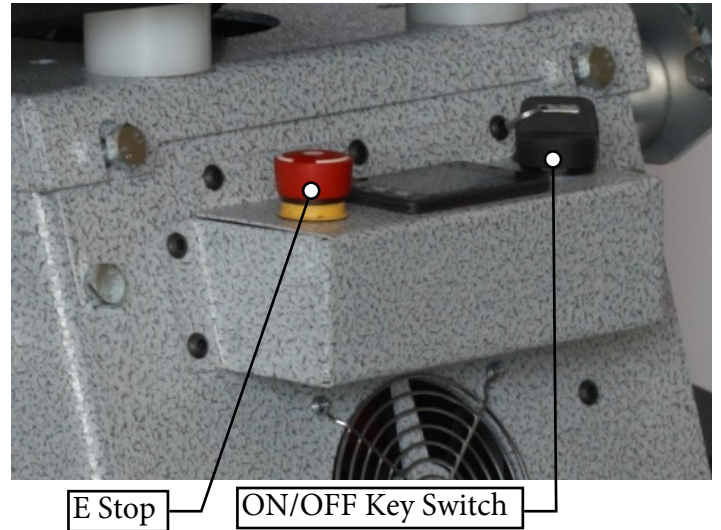

Directional Control Handles: Swing out to provide easy access to the seat.

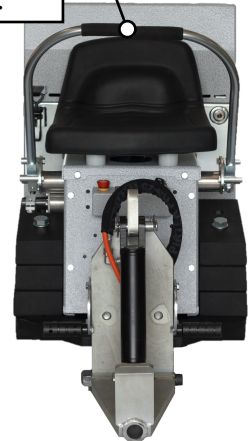

### 5.2

#### Safe operation

To move the machine use the control handles. Pushing both handles forward will move the machine straight forward. Pulling both handles backward moves the machine straight back. Use the handles independently to turn the machine. Use slow smooth movements with the control handles for the best control. Operator must keep good situational awareness avoiding people and job site hazards.



# 5 OPERATION

## 5.3 Removal of floor coverings



### VCT Tiles

Keep blades sharp! Keep your work area clean and clear of debris. Always wear eye protection when working with the machine.

Never use a blade wider than the size of the tile being removed. If material being removed will not come up clean or the machine jumps out of the work continuously, reduce blade size to a smaller blade until proper blade size is found or use a smaller portion of the blade.

### Vinyl-, Rubber, PVC, Direct Glued Carpet



Before starting the machine, cut the flooring into strips approximately the same width as the blade. Then use the machine to take up the strips. Pre-scoring carpet / sheet goods makes removed material easier to handle and extends the runtime of the machine. For best results use a stand-up scoring tool

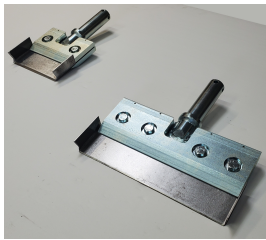

If removing soft flooring with a strong bond, the self-scoring blade can also be used. Cut ditches into the floor then demo perpendicular to the ditch to make strips that are easy to handle. Keep debris cleaned off the floor and out from under the machine. This will reduce the chance of carpet scrap getting wrapped around the wheels and tangling with the machine.

### Ceramic and other types of floor tiles

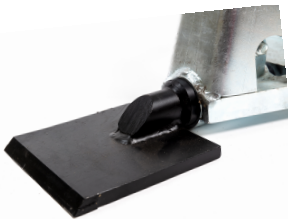

Everyone in the area must be wearing safety glasses before removing tile. Use a durable sheet material such as hard board to protect delicate wall surfaces like glass or finished wood. Using a hammer and chisel or electric demo hammer remove a tile in a clear area of the work space to open up the floor. Beginning at a doorway with an open edge is another way to start removing tile but can be more difficult to maneuver than opening a space in the middle of the room. Use a small heavy blade or preferably a carbide shank at a low angle to remove tile. Avoid removing tile at a high angle as this is less efficient and will shorten the life of your tooling. Open a line of tile across the room and then work perpendicular to that line in short passes along the line. Keep debris cleaned out from under the machine. Use a stiff broom to push debris out of the way. Debris is more easily pushed on the floor not yet removed. It is best to stop and clean the floor regularly rather creating a large volume of debris and working on top of the mess. Use a water sprayer to mist debris before pushing to reduce dust. After removing the tile use a water sprayer to mist any remaining thin-set or mortar until it has the consistency of damp sand then re-scrape at a high angle with a sharp carbide. DO NOT over water the floor. Too much water will create a slippery mess.

## 5 OPERATION

### 5.4 Battery System

#### Summary:

The ES1300 uses a 48V Lithium Battery. For charging and battery information refer to the attached manufacturers manual. The battery is installed under the hood on the back of the machine. The blue plug on the battery functions as an emergency disconnect and the charging point for the battery. The machine is equipped with a state of charge display and a low voltage interrupt "L.V.I."

#### Low Voltage Interrupt:

The L.V.I. will turn off the machine if the battery is in danger of being over discharged. The machine will alert the operator with an audible beep when the cut off voltage is near. Once the cut off voltage is reached the machine will shut off. The operator can override the L.V.I. by holding the key switch in the start position to move the machine to a charging location or out of a dangerous position such as a ramp or lift gate.

#### State of Charge Display:

The S.O.C. display shows the percentage of charge in the battery as well as voltage, amp draw, and an instantaneous run time estimate. The S.O.C. MUST be reset to 100% when a fully charged battery is installed. To reset the S.O.C. press and hold the up arrow on the SOC until the "%" shows 100. The display will immediately drop to 99% after reset. If a battery is partially charged the battery percentage on the S.O.C. WILL NOT BE CORRECT. The voltage will always be correct. Once the voltage at idle is showing 44 VDC the battery is depleted and continued use will activate the L.V.I.

The estimated runtime will fluctuate based on current amp draw of the machine. While the machine is idling the runtime will show a high number i.e. "4 Hours" under a heavy load the runtime will drop to low number i.e. " 1 Hour" The median of the high and low runtime number will be an approx runtime to expect. For additional information on the S.O.C. display refer to the enclosed Linex Manual

#### How to Improve Runtime:

- Keep the blade sharp. A dull blade is harder to push than a sharp blade.
- Use a low blade angle and properly adjusted slide plate when removing material. A high angle makes the machine work harder.
- Avoid turning the machine from a dead stop with the blade on the floor. Lift the blade when moving from one work area to another
- Turn the machine off when waiting for helpers to clear debris.
- On difficult jobs; especially heavily glued carpet, use a smaller blade. The machine will run longer and faster with a lower amp draw.



## 6 MAINTENANCE

### 6.1 Sharpen blades

Dull blades greatly reduce machine performance.  
Sharpen or replace the blade if necessary.

#### Standard blades

When used continuously, the blades develop a back bevel on the edge

The blade is only really sharp, when the back bevel is completely removed.

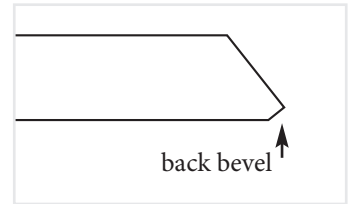

- Always wear gloves and safety glasses.
- Grind the blade with a grinding wheel of 120 grit or finer.
- Move the grinder along the edge of the blade and hold the grinder at the correct angle to the blade.
- Grind until the blade is sharp.
- Be careful not to catch the grinding disc on the edge or corner of the blade.



#### WARNING! Risk of injury!

Blades are sharp. Be extremely careful.



#### NOTE! Recommendation for optimal use of blades

- Thinner blades are easier to sharpen, but are easier to break.
- It is easier to sharpen the dull blades on a bench grinder or with a belt sander.
- If using an angle grinder be careful to avoid catching the disc on self scoring wings or grinding toward the sharp edge.

1. To sharpen the blade while mounted to the machine follow these instructions:

- Keep the blade secured in the machine.
- Block up front of machine so blade is off the floor and the machine is stable.
- Sharpen the blade with a 5" diameter disk with 120 or finer grit.
- Be careful not to catch disk on edge or corner of blade.

2. A fine tooth file can be used to sharpen some blades but is considerably slower than using a grinder.



bevel down



bevel up



Sharpening with a fine-toothed file

#### Self-scoring blade

It is important to keep the "wings" of the self-scoring blades sharp. Use a file at the "wing" edge. Sharpen the flat end of the blade exactly as described above.

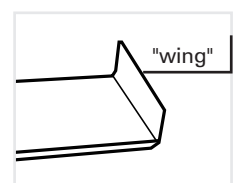

#### Shanks with carbide tip

To sharpen carbide tipped shanks a green silicon carbide grinding wheel or a diamond wheel is required. Wear a mask to protect from the hazardous dust caused by grinding carbide.

## 6 MAINTENANCE

### 6.2 Maintenance schedule



Perform maintenance outside of hazardous areas. Maintenance work must be carried out with the machine switched off and disconnected from the battery to prevent accidental start-up of the machine:

- Disconnect the battery

#### **Maintenance by the user**

Daily before you start work

- Clean the wheels, they need to be free of accumulated debris.
- Checking the wheels and castor for damage, they must have sufficient rubber and no flat spots.
- Check if all safety devices are working and are installed.
- Check for hydraulic oil leaks with the machine off.



#### **WARNING! Risk of injury by hydraulic fluid!**

Never inspect hydraulic components while the machine is running. Never feel pressurized hose assemblies to find leaks with the machine running.

Leaking pressurized hydraulic fluids may develop a mist or fine spray liquid that squirts or explodes on ignition and is capable of injecting into flesh and causing serious injury.

#### **If hydraulic fluid leaks**

- Keep ignition sources away
- With machine off look for the source of the leak
- A loose fitting is the most common source of a leak
- Use an absorbent pad and degreaser to clean up spilled oil.
- Residual oil can be found after fixing a leak for a period of days if it gets under panels and other components.
- If the source of a leak cannot be fixed contact the manufacturer or a hydraulic repair shop.

Replacement of hydraulic oil and oil filter- see chapter 6.3

#### **Recommended Maintenance by the manufacturer**

- Check oil level at sight gauge before operating
- Inspect hardware on panels and controls and tighten when required
- Check torque on wheel motor castle nut and lug nuts regularly
- Inspect electrical cables and hydraulic lines every 6 months, replace if there are any signs of wear or damage
- Change oil and filter annually
- Use only original equipment manufacturer parts for replacement.

## 6 MAINTENANCE

### 6.3

#### Hydraulic oil

##### **Dangers for people and the environment**

Hydraulic oils are flammable. Vapors released when exposed to very high temperatures and spray can form explosive mixtures with air.

There is a risk of ignition of oil-soaked clothing.

Frequent or prolonged contact with the products, even through oil-soaked clothing, can cause skin diseases, e.g. inflammation, rash, oil acne. Products exposed to high temperatures may accumulate with hazardous substances. Water pollutant.

##### **Protective measures and rules of conduct**

Drain hydraulic fluid into a drip pan, avoid splashing. Do not overfill drip pans and do not use to store other materials.

Keep away from ignition sources, do not smoke. Do not mist lubricants.

Keep container closed and protect from heat.

Keep soaked cloths in non-combustible, closed containers.

Replace cleaning rags regularly.

Mark filled containers, replace defective markings.

Never use food containers or containers to be confused with them.

Hand protection: for long-term use resistant chemical protective gloves

Skin protection: Avoid contact with skin and clothing.

Immediately change soaked clothing and put on only after cleaning. Do not put smeared cloths in the pockets of work clothes. Do not use solvents, thinner, or other harsh chemicals for cleaning hands or body.

##### **Procedures in case of incidents**

leak: After leakage, immediately use an absorbant mat or material to contain the spill. Pickup this contaminated material and dispose in a proper container. Clean the floor thoroughly so there is no slippery surfaces.

fires: Have a fire extinguisher available for fire class B. Do not extinguish with water. In case of fire, there is a risk of the hydraulic reservoir bursting due to the boiling liquid and expanding vapors.

escape route: See marking of escape routes and emergency exits

##### **First aid**

after skin contact: Thoroughly wash with soap and water, remove previously soaked clothes.

after eye contact: Rinse with an open eye and toward the outer eye for ten minutes in running water, visit a eye specialist.

after swallowing: Do not induce vomiting, consult a doctor.

after penetration of oil: After penetration of oil under the skin immediately consult medical attention!

##### **Proper disposal**

Collect waste in labeled non-combustible containers; Keep waste containers and empty containers closed, empty at the latest at the end of the shift or remove them from the work space.

## 6 MAINTENANCE

### 6.3 Replacement of hydraulic oil

#### Resources

Hydraulic oil: Shell Tellus S2 MX 46

Capacity: 7 Gallons

#### ATTENTION !

Keep the hydraulic fluid clean and at the specified level. Incompatible fluids can damage the unit or cause serious injury.

#### Level of hydraulic fluid

The machine is ready for operation when delivered, it is filled with hydraulic oil.

The full level is shown by the presence of oil in the site gauge shown on page 13 of this manual.

Check the hydraulic fluid level if there is a leak, damaged or broken hose or loose fitting.



#### Draining / Filling Hydraulic Fluid

To drain the hydraulic follow this procedure:

1. Disconnect the battery
2. Remove the breather from the top of the pipe under the battery hood
3. Remove 1 wheel from the machine to allow easy placement of a 5 gallon bucket or use a funnel that fits under the back corner of the hydraulic reservoir.
4. There are two drain plugs on the bottom rear corners of the reservoir. Remove the drain plug from one side and catch the oil in a pail until the approx 4 gallons has been removed. Switch to a second pail and continue draining until flow stops.
5. Repeat step 4 on the opposite side of the reservoir to empty the remaining one to two gallons of oil in the reservoir.

To fill the reservoir follow this procedure:

1. Make sure drain plugs are installed
2. Remove the breather pipe from the back of the reservoir under the hood
3. Place a funnel into the bung in the reservoir
4. Carefully fill the reservoir allowing air to escape as you pour.
5. Watch the sight gauge as you near 7 gallons. **DO NOT OVER FILL THE RESERVOIR**
6. Replace the breather pipe and breather
7. Confirm oil level is correct and check for any spilled oil



## 7 Attachments:

---

1. LNEXT Battery Monitor (S.O.C. Display)
2. Dakota Lithium Battery Guide
3. Safety Data Sheet for Dakota Lithium Battery
4. Safety Data Sheet for hydraulic oil



## 7 Attachments

7.1

# LNEX COLOR

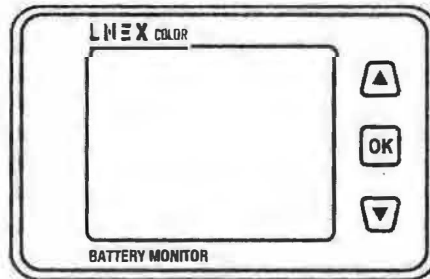

## BATTERY MONITOR USER MANUAL

### Notice

---

- Please read this guide carefully to avoid incorrect connections that can cause the battery monitor to malfunction and/or create a fire hazard. Disconnect the negative pole of the battery before installation.
- LNEX Battery Monitor can't be exposed in the sun for a long time or in the environment with large amounts of ultraviolet radiation when using or storing, in winter ( $< -10^{\circ}\text{C}$ ) and summer ( $> 60^{\circ}\text{C}$ ) otherwise the life span of the LCD will be shortened.
- Do NOT let the positive (+) and negative (-) terminals of the battery touch each other.
- Never connect a load to a battery without using fuses or circuit breakers.

### Compatibility

---

The LNEX Battery Monitor is suitable for lithium batteries, lead acid batteries and nickel-metal hydride batteries that have voltage from 10V to 120V.

1



## 7 Attachments

### About

The LNEX Battery Monitor is a high precision device (also known as coulometer), which can test the voltage, current, and capacity of a battery to help users know the state of charge at any time. The LNEX Battery Monitor has a memory function which allows users to set a low voltage capacity alarm. It is suitable for RV, electric vehicle, portable power station, e-bike, electric wheelchairs, and so on.

### Package List

LCD Interface*1	500A Shunt/Sampler*1
10ft (3m) Shielded Wire*1	10ft (3m)20 AWG B+ Wire*1
hand wrench*1	250A Battery Terminals *2

### Parameter

2

Model		VA9810
Measuring range	Voltage	8V~100V
	Current	0.2A~500A
	Capacity	0.1AH~99999AH
	Power value	60KW
Accuracy	Voltage	±1%
	Current	±1%
Display		2.4 inch color LCD display
Power consumption		Working: 0.3W      Static: 0.2W
Communication baud rate		9600bps
Measurement rate		20 times/sec
Display board size		88*18*55mm
Shunt size		86*37*50mm

3

## 7 Attachments

### Dimension

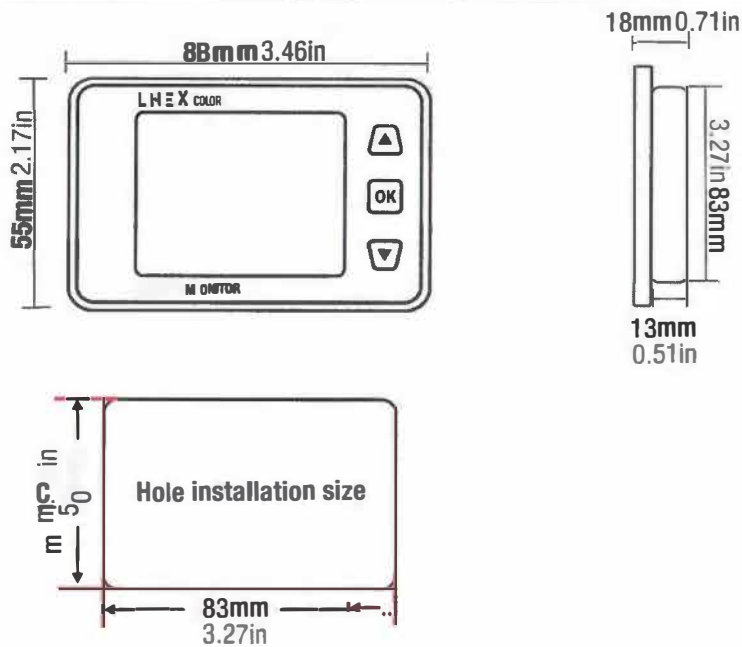

4

### Installation

- First, connect the Shunt in series to the negative circuit of your battery. B- of shunt connects to B- of the battery. P- of shunt connects to P- of output and C- of charge.
- Then take a wire of 0.3-0.75 mm<sup>2</sup>. One end of the wire connects to positive of battery, another end connects to B+ of Shunt.
- Finally connect the Shunt to the LNE X Battery Monitor by the shielded wire and the screen of the LNE X Battery Monitor display should turn on.

**Attention:** Please connect as shown. The shunt must be series connected to the negative circuit, DO NOT connect to the positive circuit.

5

## 7 Attachments

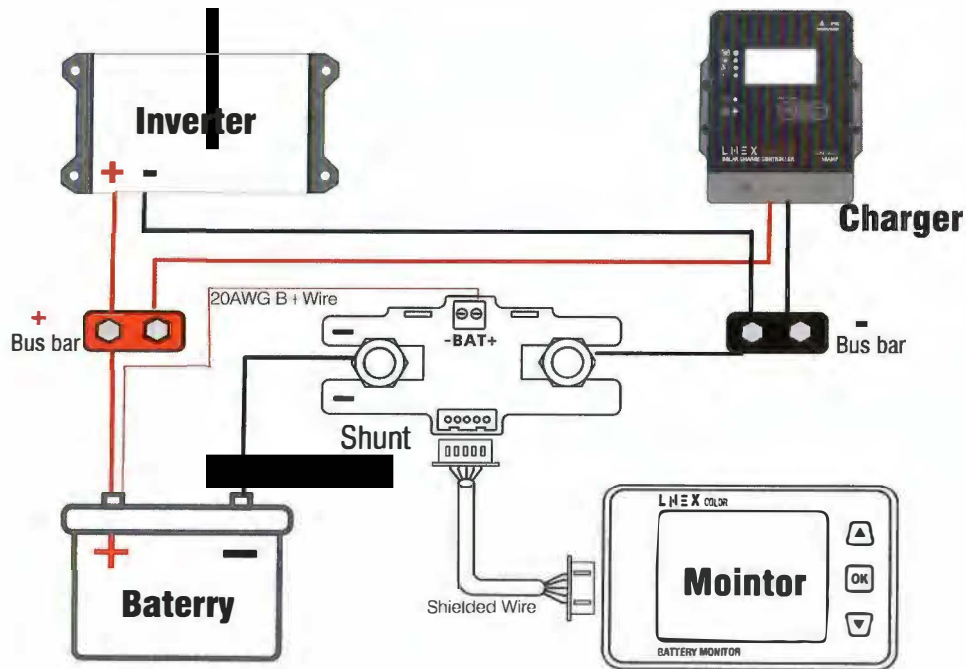

6

### Operation

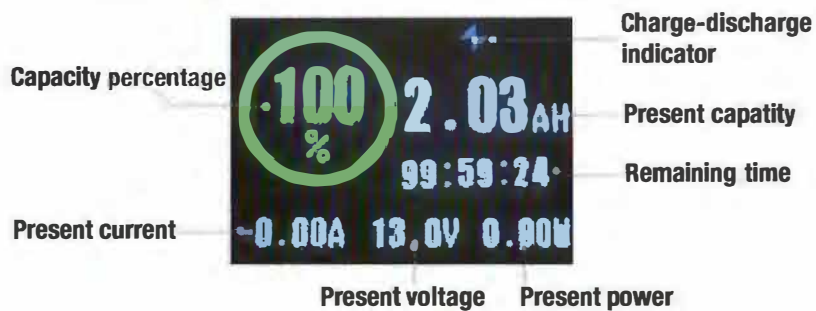

### use steps

1. Connect and check the current: Power on after completing the connection as shown, the screen should display capacity percentage. If the screen has no response, please check the connection. Then charge or discharge the battery and check whether the display current is equal to the actual current. If the deviation is large, please check the connection.

7

## 7 Attachments

**2. Capacity calibration:** On first use, the percentage and capacity are not the actual value, you need to calibrate the capacity to either 100% or 0%.

First set the usable AH capacity of the battery as the preset AH capacity. For Lithium and Sealed Lead Acid batteries to calibrate to 100% charge the battery fully and hold the "up" key for 3s to set the capacity to 100%. For Lithium batteries to calibrate to 0% discharge the battery completely and hold the "down" button key for 3s to set the capacity to zero. This will only have to be done on initial installation of the LNEX Battery Monitor or if the Battery Bank is replaced.

**3. Check and reset the actual capacity:** If you find the displayed capacity doesn't match the actual capacity during use, please check and reset the actual capacity.

For Lithium batteries discharge the battery to 0% and hold the "down" key for 3s to set the capacity to 0, then set the preset capacity as large as possible.

Now charge the battery fully and the displayed AH capacity should be the actual usable capacity. Then set the displayed AH capacity as the preset AH capacity.

For Sealed Lead Acid batteries it is recommended to set the AH lower than the usable rating after conducting a capacity test or consulting the battery manufacturer.

8

### User settings

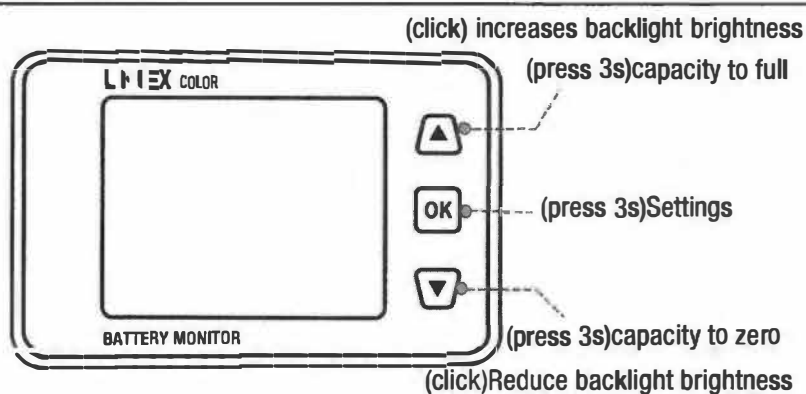

Enter the parameter setting function, short press the ▼ or ▲ key to switch the setting parameters, short press the OK key to select the adjustment parameter, short press the ▼ key to switch the step value of the adjustment parameter, short press the ▲ key to change the parameter value, long press the "OK" key for 5 seconds. The above exits the parameter setting function and saves the data.

9

## Setting lists

**01."CLR"** current clearing function, when the no-load current is not zero, enter this option, click the up button to clear the no-load current.

**02."BAT"** sets the capacity of the battery, An initial capacity has been set at the factory, please set it according to the real capacity of your battery.

**03."BPC"** sets the percentage of remaining capacity, please set it according to the real capacity of your battery.

**04."LED"** sets the backlight brightness of the LCD display, 0-10 is set according to the needs. The higher the level, the higher the brightness.

**05. "STE"** sets the value of the LCD screen entering sleep standby time. When the running time is greater than the set value, the LCD screen will turn off.

**06. "STI"** sets the sleep standby current value, when the measured current is less than the set value , the LCD will go into a low power sleep mode, When the battery current rises over set value the LCD will wake up. ("STE" must be turned on, otherwise the setting is invalid).

**07."BKC"** sets the color model of the LCD interface, with black and white and color

10

options available;

**08."LBR"** backlight breathing light alarm effect switch, when the remaining power is less than 20% or the voltage is lower than LVP, it will flash and alarm, and it will also display breathing when the charging current is greater than STI.

**09."PAI"** current is corrected to 0; after the no-load current is cleared, the shunt has a temperature drift so that the current value is not zero; Parameter setting can be performed, the current value is lower than the set value, and the current current value is zero.

**10. "LVP"** battery low voltage alarm value; When the voltage is lower than the set value, the capacity will be automatically set to 0%.

11

## Troubleshooting

- When the battery current is low the LNEX Battery Monitor will enter a low power (sleep mode) and the backlight will turn off, press any button and the backlight will turn on .
- When the current changes frequently the data acquisition may produce an error, and it may affect the accuracy.
- When charging or discharging. The LNEX Battery Monitor will be working and the capacity displayed will be real-time numbers.
- When the battery is charging, the monitor shows a negative amp reading, and

when using the battery, it shows positive amps, the B- and P- of the shunt are wired inversely.

# How to Charge Dakota Lithium and LiFePO4 Batteries

September 22, 2021

## Do I need a special charger for lithium batteries?

All Dakota Lithium and most lithium-ion batteries require a higher voltage than lead acid batteries to fully charge and perform best when charged with a lithium specific battery charger that charges at 57.6 Volts. This includes Dakota Lithium Iron Phosphate (LiFePO4) and Lithium Nickel Manganese Cobalt (NMC) batteries. A battery charger for a lead acid battery will work to partially charge a lithium battery, but only to a maximum of 60-80% of the lithium battery's capacity. The voltage level of a full lead acid battery is about a volt lower than the voltage of a full lithium battery. As a result, the lead acid charger will think the battery is "full" once it reaches the lower voltage that is associated with a full lead acid battery. The result is lead acid battery chargers work, but only charge to 60-80% of the lithium battery's capacity. Please note that lead acid chargers do not damage the battery, they just prevent the battery from reaching it's full capacity and performance potential. The performance limitations of lead acid chargers being used for lithium batteries is significant enough that most lithium battery owners prefer to use lithium specific chargers. Lithium specific chargers maximize the performance and value of a lithium battery.

## What voltage is required to charge my lithium batteries?

Dakota Lithium Iron Phosphate (LiFePO4) 48V batteries should be charged at 57.6 Volts (V).

Dakota Lithium Battery Voltage | Recommended Charging Voltage | Recommended Charging Speed (C)

48 Volts |

57.6 Volts |

<0.3C (3 hours or more)

# How fast can I charge my battery?

Calculate the charge time by dividing the capacity of the battery (Ah for Amp Hours) by the charger output (A for Amps). For example, a [12V 100Ah Dakota Lithium battery](#) includes a free [12V 10A LiFePO4 battery charger](#) that charges the battery from empty to full in 10 hours (100 Ah divided by 10 A = 10 hours).

For the longest lifespan LiFePO<sub>4</sub> batteries should be charged at less than .3C, or 3 hours or more of charging time. But all Dakota Lithium batteries can be charged at a rate of up to 1C and a charging time as low as 1 hour. For other brands confirm that max charging amps in the battery's specifications. 0.5C (2 hours) is a common max charging speed for lithium batteries.

Charging time does impact lifespan. Charging at 1C / 1 hr regularly will reduce the lifespan of lithium batteries. The Lithium Iron Phosphate (LiFePO<sub>4</sub>) molecules that make up a Dakota Lithium, or any LiFePO<sub>4</sub> battery, are stressed each time you charge a battery. Overtime those molecules fracture, break apart, and lose their ability to hold a charge. This is why after 2,000 to 4,000 recharge cycles at <0.3C a LiFePo<sub>4</sub> battery will have <70-80% of the original capacity, and why Dakota Lithium batteries reach their half-life (<50% of capacity) at around 6,000 recharge cycles. A higher charge rate will increase the stress on the molecules, leading to a shorter battery lifespan.

[48V 96Ah Battery](#) | [48V 8A LiFePO4 charger](#) (12 hrs) | [48V 15A LiFePO4 charger](#) (6 hrs)

## Should I use float chargers or battery maintainers for my lithium battery?

No, LiFePO<sub>4</sub> batteries should be disconnected from the charger when fully charged. Float charging, or maintainers are not good for lithium batteries. Keeping a constant float charge or topping off charge also can cause metal plating and will reduce the lifespan of lithium batteries. Dakota Lithium batteries also have a low self-discharge rate of <5%

## How do I know my charging is working?

The light on the battery charger turns green when plugged into an outlet. While charging, the light turns red. It turns green again when the battery is fully charged. The charger should be disconnected when the battery is fully charged to prevent over-charging which can cause permanent battery damage.



# Why won't my lithium battery charge? How to troubleshoot battery problems

Checking the battery and a charger with a voltmeter is a good place to start when experiencing issues. Test the battery before and after attempting a full charge, and when the battery is depleted. Also, test the output on the charger, it should measure 57.6V when working properly. Getting a voltage charge of less than 1V is evidence that the B.M.S. has been triggered on the battery to protect it from a potentially dangerous condition. The B.M.S. can usually be reset by charging the battery with a Dakota Lithium charger.

## What is the battery voltage when my battery is full or depleted?

Batteries measure around 14.4V when they are fully charged and quickly drop to about 13.4V when the charger is removed. They provide consistent power between 13.4 to about 12.8V and quickly deplete to 9.7V at the end of the discharge. Dakota Lithium Iron Phosphate batteries have a flat voltage curve. This means that the voltage will be fairly steady throughout use, and only drop below a useful voltage when the battery is nearly empty. Lead acid batteries have a steep voltage drop and it is common that a lead acid battery's voltage is no longer useable when the battery still have 60% of capacity left. This flat voltage curve is why Dakota Lithium batteries have twice the usable power even though the battery has the same amount of energy inside the battery. A 100Ah Dakota Lithium battery will last twice as long as a 100Ah AGM or lead acid battery even though the name plate or energy rating is the same. Please note: Seeing a low voltage of <1V is evidence that the B.M.S. is triggered.

## What is the B.M.S.?

B.M.S. – Battery Management System – is the intelligent component of the battery which monitors and manages several aspects of its performance, including charge and discharge rates. The B.M.S. also provides safety protection in the case of short circuit, over charging, or the battery getting too hot. The B.M.S. will trigger and shut down the battery in instances when the charge/discharge current is too high, the temperature is too high, or to prevent over charging or over discharge. BMS design may vary with brand. Dakota Lithium engineers design the battery management system microchips for our batteries in house to meet specific safety standards including cold temperature charging protection, high temperature protection, cell balancing, and other features that extend the lifespan and performance of the battery. Please note: Seeing a low voltage of <1V is evidence that the B.M.S. is triggered.

## How do I turn a battery back on after the battery management system has turned it off?

If available use a voltmeter to check the voltage of the battery. Seeing a low voltage of  $<1V$  is evidence that the B.M.S. is triggered. To re-start the battery simply connect to a Dakota Lithium LiFePO<sub>4</sub> charger to the battery. The charger will tell the BMS inside the battery to turn on the battery and re-charge.

## How can I calculate the battery's run time?

Calculate the battery run time by dividing the battery capacity (Ah) by the power draw of anything connected to the battery (A). For example, an electric cooler that a power draw of 1 amp can be powered for 100 hours by a Dakota Lithium or LiFePO<sub>4</sub> battery or 40-50 hours by an AGM or lead acid battery.

## What happens inside my battery when charging or discharging?

Dakota Lithium batteries transfer a charge via lithium-ions between lithium iron phosphate in the cathode and graphite in the anode using intercalation. The ions never become lithium metal and stay in the ion state, which makes the batteries rechargeable.

## At what temperatures can I charge and operate my batteries?

LiFePO<sub>4</sub> batteries can be safely discharged below freezing temperature and provide up to 70% of their power, VRLA batteries do not work at that temperature. Dakota Lithium batteries can also operate safely in temperatures up to 149°F, while VRLA batteries' service life halves every 18°F increase in temperature over 120°F. LiFePO<sub>4</sub> batteries can be charged in environments up to 113°F but should not be charged in direct sunlight above 90°F. Charging lithium iron phosphate batteries below 32°F not only makes your batteries unsafe, but it also will drastically and permanently reduce the capacity.

## How should I store my battery? Does it self-discharge?

LiFePO<sub>4</sub> batteries have a low self-discharge rate of 3 – 5% per month, so they can be left in a partially discharged state for over a year without damaging the battery. This is 5X less than the self-discharge rate of VRLA batteries, but it is higher than some other lithium based systems.

L.F.P. batteries should be stored well charged at a temperature between 40 – 95°F, however, they need to be above 32°F to charge. We recommend charging your lithium batteries every two months to ensure they do not completely drain.

# Safety information:

Do not charge any damaged batteries.

Do not short circuit lithium batteries.

Do not heat over 140°F

Do not exceed the max discharge specifications of the battery (for example, if the battery has a max discharge of 10 amps do not try to run a trolling motor off of it that pulls 20 amps)

Do not puncture the outer case or disassemble the battery

Batteries over 300Wh are subject to hazmat regulations when shipping.

When shipping a battery plenty of anti static bubble wrap should be used to protect it from blunt damage. The terminal posts should be removed, if possible, to prevent accidental shorting.

## **Safety: How Safe are Lithium Iron Phosphate Batteries?**

We have all heard and read past accounts of lithium batteries exploding or catching fire when compromised during trauma or over charging. But with the development of new chemistries and advanced manufacturing techniques, lithium ion technology is now one of the most popular battery options available. A common misunderstanding is that all lithium ion batteries are the same. There are different chemistries available that provide various advantages and disadvantages. Another factor in safety is the manufacturing of the battery and the technology of the battery including battery management systems (BMS) to monitor the battery's performance.

## **BATTERY MANAGEMENT SYSTEM (BMS) – Ensures safety and long battery lifespan**

All Dakota Lithium batteries include an active BMS protection circuit that handles cell balancing, low voltage cutoff, high voltage cutoff, short circuit protection and temperature protection for increased performance and longer life.

Safety measures provided by the BMS prevent overheating. All Dakota Lithium batteries have a BMS that can support linking batteries in series or parallel.

## LITHIUM IRON PHOSPHATE – LiFePO<sub>4</sub>

Different Li-ion batteries use different chemistries. Dakota Lithium exclusively engineers our batteries using lithium iron phosphate or LiFePO<sub>4</sub> for short. Lithium Iron Phosphate batteries are the safest lithium battery chemistry. Unlike the cell phone battery in your pocket, or the laptop battery on your desk, the structural stability of LiFePO<sub>4</sub> results in significantly less heat generation compared to other lithium chemistries.

### NO THERMAL RUNAWAY – Dakota Lithium cells do not produce oxygen

The main cause of fire or explosion of a lithium ion battery is due to the cells being compromised or ruptured, which causes thermal runaway. Without proper management, thermal runaway may result in fire. Dakota LiFePO<sub>4</sub> is extremely stable and does not produce the oxygen needed to aid thermal runaway and unlike other lithium battery chemistries will not result in a catastrophic meltdown.

### 100% COBALT FREE – No rare earth elements

NCM and other lithium ion chemistries that contain rare earth elements such as Colton or Cobalt produce oxygen and toxic fumes when ruptured, leading to fire. Dakota Lithium does not contain rare earth elements, and does not produce oxygen or a fire.

### CERTIFICATIONS – Tested and certified for safety and reliability

Dakota Lithium batteries are UN 38 certified and built from grade A cells. Dakota Lithium's cells are UL1642 certified and have been tested per IEC62133 standards. UN Manual of Tests and Criteria certified, and meets all US & International regulations for air, ground, marine, and train transport. Select battery models are ISO Certified ISO 9001:2008 Quality Management System & ISO 14001:2004 Environmental Management System for use in industry applications. IEC62133 certifications and additional laboratory services are available as required by our OEM clients.

### INSTALLATION & CARE – Treat your batteries right

When proper installation and battery care is followed, your LiFePO<sub>4</sub> battery will be safe and reliable for many years. This includes making sure all connections are tight and proper wiring sizes are used, compatible chargers and charging components are used, and the batteries are used for purposes that they are designed for.

7.3

**SAFETY DATA SHEET**

**LITHIUM PHOSPHATE (LiFePO4)**

**1. PRODUCT IDENTIFICATION**

Product Name: LiFePO4 Rechargeable Battery  
 Chemical System: LiFePO4

**2. COMPOSITION / INFORMATION ON INGREDIENTS**

IMPORTANT NOTE: The battery cell should not be opened or exposed to heat as exposure to the following ingredients contained within could be harmful under some circumstances.

Weight %	Component	CAS No.	PEL	TLV
40	Lithium Iron Phosphate LiFePO4	15365-14-7	10.0 mg/m3 (as iron fume)	5.0 mg/m3
30	Graphite (C)	7440-44-0	2.5 mg/m# (as dust)	2.0 mg/m3 (as dust)
10	Organic Electrolyte	N.A.	None Established	None Established
5	Aluminum	7429-90-5	None Established	None Established
5	Copper	7440-50-8	None Established	None Established

Weight % listed is based on approximate percent of the average weight of the battery

**3. HAZARDS IDENTIFICATION**

For the battery cell, chemical materials are stored in a hermetically sealed Aluminum laminated case, designed to withstand temperatures and pressures encountered during normal use. As a result, during normal use, there is no physical danger of ignition or explosion and chemical danger of hazardous materials' leakage. However, if exposed to a fire, added mechanical shocks, decomposed, added electric stress by miss-use, the gas release vent will be operated. The battery cell case will be breached and hazardous materials may be released.

Moreover, if heated strongly by the surrounding fire, hydrogen fluoride gas may be emitted.

Most important hazards and effects

Human health effects:

- Inhalation: The steam of the electrolyte has an anesthesia action and stimulates a respiratory tract.
- Skin contact: The steam of the electrolyte stimulates skin. The electrolyte skin contact causes a sore and stimulation on the skin.
- Eye contact: The steam of the electrolyte stimulates eyes. The electrolyte eye contact causes a sore and stimulation on the eye. Especially, strong inflammation of the eyes is caused.

Environmental effects: Do not throw out it into the environment.

Specific hazards:

If the electrolyte contacts with water, it will generate detrimental hydrogen fluoride.  
 Since the leaked electrolyte is inflammable liquid, do not bring close to fire.

#### 4. FIRST-AID MEASURES

##### Spilled internal cell materials

Inhalation: Make the victim blow his/her nose, gargle. Seek medical attention if necessary.

Skin contact: Remove contaminated clothes and shoes immediately. Wash extraneous matter or contact region with soap and plenty of water immediately.

Eye contact: Do not rub in eyes. Immediately flush eyes with water continuously for at least 15 minutes. Seek medical attention immediately.

Ingestion: Make the victim vomit. Seek medical attention.

#### 5. FIRE-FIGHTING MEASURE

Suitable extinguishing media: Plenty of water, carbon dioxide gas, nitrogen gas, chemical powder fire extinguishing medium and fire foam.

Specific hazards: Corrosive gas may be emitted during fire.

Specific methods of fire-fighting: When the battery burns with other combustibles, use the fire-extinguishing method which corresponds to the combustible items. Extinguish a fire from an up-wind position as much as possible to avoid inhalation.

##### Special protective equipment for firefighters:

Respiratory protection: Respiratory equipment or, if not available, dust mask.

Hand protection: Protective gloves.

Eye protection: Goggles or protective glasses designed to protect against liquid splashes

Skin and body protection: Protective clothing.

#### 6. ACCIDENTAL RELEASE MEASURES

Spilled internal cell material, including leaked material from a battery cell, is to be dealt with carefully.

##### Precautions for human body:

Remove spilled materials with protective equipment (protective glasses and protective gloves).

Do not inhale the gas as much as possible. Moreover, avoid touching as much as possible.

##### Environmental precautions:

Do not throw out into the environment.

##### Method of cleaning up:

The spilled solids are put into a container.

The leaked materials should be wiped off with dry cloth.

##### Prevention of secondary hazards:

Avoid re-scattering.

Do not bring the collected materials close to fire.

## 7. HANDLING AND STORAGE

### Handling

Prevention of user exposure: Not necessary under normal use.

Prevention of fire and explosion: Not necessary under normal use.

Precaution for safe handling: Do not damage or remove the external casing.

Specific safe handling advice:

- Never throw out cells in a fire or expose to high temperatures.
- Do not soak cells in water or seawater.
- Do not expose to strong oxidizers.
- Do not give a strong mechanical shock or fling.
- Never disassemble, modify or deform.
- Do not connect the positive terminal to the negative terminal with electrically conductive material.
- In the case of charging, use only dedicated charger and charge according to the conditions specified by the user manual.

### Storage

Storage conditions: Avoid direct sunlight, high temperature, and high humidity. Store in cool, dry place (temperature: 20 - 35°C, humidity: 45 - 85%).

Incompatible products: Conductive materials, water, seawater, strong oxidizers and strong acids. Packing material: Insulating and tear-proof materials are recommended.

## 8. EXPOSURE CONTROLS / PERSONAL PROTECTION

Engineering measures: Use adequate ventilation and recommended personal equipment.

Control parameters:

Common chemical name / General name	ACGIH (2002) TLV-TWA	BEI
Lithium Iron Phosphate		-
Aluminum	10 mg/m <sup>3</sup> (metal coarse particulate) 5 mg/m <sup>3</sup> (flammable powder) 5 mg/m <sup>3</sup> (weld fume)	-
Carbon	2 mg/m <sup>3</sup>	-
Copper	0.2 mg/m <sup>3</sup> (fume)	-
Polyvinylidene Fluoride (PVDF)		-
Organic Electrolyte		-

ACGIH: American Conference of Governmental Industrial Hygienists Inc.

TLV-TWA: Threshold Limit Value-Time Weighted Average concentration.

BEI: Biological Exposure Indices.

#### Personal protective equipment

Respiratory protection: Respirator with air cylinder, dust mask. Hand protection: Protective gloves.

Eye protection: Goggles or protective glasses designed to protect against liquid splashes.

Skin and body protection: Working clothes with long sleeves and long trousers.

### 9. PHYSICAL AND CHEMICAL PROPERTIES

#### Appearance

Physical state: Solid

Form: Prismatic

Color: Metallic color (without casing)

Smell: Odorless

pH: N/A

Specific temperatures/temperature ranges at which changes in physical state occur: N/A

Flash point: N/A

Explosion properties: N/A

Density: N/A

Solubility with indication of the solvent(s): Insoluble in water

### 10. STABILITY AND REACTIVITY

Stability: Stable under normal use. Hazardous reactions occurring under specific conditions

Conditions to avoid: When a battery cell is exposed to an external short-circuit, is crushed, deformed, or exposed to high temperature above 100°C, it will generate heat and possibly ignite. Do not place it in direct sunlight or high humidity.

Materials to avoid: Conductive materials, water, seawater, strong oxidizers and strong acids.

Hazardous decomposition products: Acrid or harmful gas is emitted during fire.

### 11. TOXICOLOGICAL INFORMATION

The information of the internal cell materials is as follows:

#### Lithium Iron Phosphate (LiFePO<sub>4</sub>)

Acute toxicity: No applicable data.

Local effects: Unknown.

Sensitization: The nervous system of respiratory organs may become sensitive.

Chronic toxicity/Long term toxicity: No applicable data.

Skin causticity: Although it is very rare, a rash of the skin and allergic erythema may result.

#### Aluminum

Local effects: Aluminum itself has no toxicity. When it goes into a wound, dermatitis may be caused.

Chronic toxicity/Long term toxicity: By the long-term inhalation of coarse particulate or fume, it is possible to cause lung damage (aluminum lungs).



Graphite

Acute toxicity: Unknown. Local effects: When it goes into the eyes, it stimulates the eyes; conjunctivitis, thickening of corneal epithelium or edematous inflammation palpebra may be caused. Chronic toxicity/Long term toxicity: Since the long-term inhalation of high levels of graphite coarse particulate may become a cause of a lung disease or a tracheal disease. Carcinogenicity: Graphite is not recognized as a cause of cancer by research organizations and natural toxic substance research organizations of cancer.

Copper

Acute toxicity: 60-100mg sized coarse particulate causes a gastrointestinal disturbance with nausea and inflammation. TDLo, hypodermic - Rabbit 375mg/kg Local effects: Coarse particulate stimulates the nose and throat. Eyes will become red and painful if contact is made. Sensitization: Sensitization of the skin may be caused by long-term or repetitive contact. Reproductive effects: TDLo, oral - Rat 152mg/kg

Organic Electrolyte

Acute toxicity: LD50, oral - Rat 2,000mg/kg or more  
Local effects: Unknown.  
Skin irritation study: Rabbit - Mild  
Eye irritation study: Rabbit - Very severe

**12. ECOLOGICAL INFORMATION**

Persistence/degradability: Do not bury or throw out into the environment.

**13. DISPOSAL CONSIDERATIONS**

Recommended methods for safe and environmentally preferred disposal:

- Product (waste from residues): Do not throw out a used battery cell. Recycle it through the recycling company, or local council refuse center.
- Contaminated packaging: Neither a container nor packing is contaminated during normal use.
- When internal material is leaked from a battery, dispose of as industrial waste subject to special controls.

**14. TRANSPORT INFORMATION**

In the case of transportation, avoid exposure to high temperature and prevent the formation of any condensation.

Prevent falling, dropping and breakage.

Prevent collapse of cargo piles and water damage.

The container must be handled carefully.

Please refer to Section 7-HANDLING AND STORAGE.

The transport of Lithium ion batteries is subject to international regulation which can differ if the batteries are transported by air, sea or road. There are a range of fines for companies (including OEMs) who do not comply with these regulations.

All Tracer Power batteries, covered in this document, have met the requirements of the UN Manual of Tests and Criteria, Fifth Revised Edition (ST/SG/AC.10/11/Rev.5 section 38.3 entitled "Lithium Metal and Lithium ion Batteries") and can therefore be transported.

The UN numbers, and proper shipping names, of Lithium Ion batteries, are as follows:

UN3480 – Lithium ion batteries

UN3481 – Lithium ion batteries contained in equipment or packed with equipment

Lithium ion batteries which have been transportation tested but have a possible stored energy of >100Wh must be transported as Class 9 dangerous goods which impose strict packaging, labeling and documentation requirements on those shipping the product. Special training and certification is required for those wishing to ship class 9 dangerous goods.

There are restrictions on the number and size of Lithium ion batteries which can be taken on board aircraft (as carry on or checked in luggage).

Please contact Dakota Lithium for full details of transport requirements.

## 15. REGULATORY INFORMATION

Regulations specifically applicable to the product:

IATA-DGR (air transportation)

IMO-IMDG Code (sea transportation)

US Department of Transportation 49 Code of Federal Regulations [USA]

Wastes Disposal and Public Cleaning Law [Japan] Law for Promotion of Effective Utilization of resources [Japan]

## 16. OTHER INFORMATION

The information contained in this Safety data sheet is based on the present state of knowledge and current legislation.

This safety data sheet provides guidance on health, safety and environmental aspects of the product and should not be construed as any guarantee of technical performance or suitability for particular applications.

**SAFETY DATA SHEET**

According to OSHA Hazard Communication Standard, 29 CFR  
1910.1200

**Shell Tellus S2 MX 46**

Version            Revision Date:            SDS Number:            Print Date: 05/01/2018  
1.1                04/30/2018            800010026152            Date of last issue: 04/11/2016

---

**SECTION 1. IDENTIFICATION**

Product name                        : Shell Tellus S2 MX 46

Product code                        : 001F8439

**Manufacturer or supplier's details**

Manufacturer/Supplier            : **Shell Oil Products US**  
PO Box 4427  
Houston TX 77210-4427  
USA

SDS Request                        : (+1) 877-276-7285  
Customer Service                   :                                       

**Emergency telephone number**

Spill Information                   : 877-504-9351  
Health Information                 : 877-242-7400

**Recommended use of the chemical and restrictions on use**

Recommended use                   : Hydraulic oil

---

**SECTION 2. HAZARDS IDENTIFICATION****GHS classification in accordance with 29 CFR 1910.1200**

Based on available data this substance / mixture does not meet the classification criteria.

**GHS label elements**

Hazard pictograms                : No Hazard Symbol required

Signal word                        : No signal word

Hazard statements                : **PHYSICAL HAZARDS:**  
Not classified as a physical hazard under GHS criteria.  
**HEALTH HAZARDS:**  
Not classified as a health hazard under GHS criteria.  
**ENVIRONMENTAL HAZARDS:**  
Not classified as an environmental hazard under GHS criteria.

Precautionary statements       : **Prevention:**  
No precautionary phrases.  
**Response:**  
No precautionary phrases.  
**Storage:**  
No precautionary phrases.  
**Disposal:**

# SAFETY DATA SHEET

According to OSHA Hazard Communication Standard, 29 CFR 1910.1200

## Shell Tellus S2 MX 46

Version 1.1      Revision Date: 04/30/2018      SDS Number: 800010026152      Print Date: 05/01/2018  
Date of last issue: 04/11/2016

No precautionary phrases.

### Other hazards which do not result in classification

Prolonged or repeated skin contact without proper cleaning can clog the pores of the skin resulting in disorders such as oil acne/folliculitis.

Used oil may contain harmful impurities.

High-pressure injection under the skin may cause serious damage including local necrosis.

Not classified as flammable but will burn.

The classification of this material is based on OSHA HCS 2012 criteria.

Under normal conditions of use or in a foreseeable emergency, this product does not meet the definition of a hazardous chemical when evaluated according to the OSHA Hazard Communication Standard, 29 CFR 1910.1200.

### SECTION 3. COMPOSITION/INFORMATION ON INGREDIENTS

Chemical nature : Highly refined mineral oils and additives.  
The highly refined mineral oil contains <3% (w/w) DMSO-extract, according to IP346.

\* contains one or more of the following CAS-numbers: 64742-53-6, 64742-54-7, 64742-55-8, 64742-56-9, 64742-65-0, 68037-01-4, 72623-86-0, 72623-87-1, 8042-47-5, 848301-69-9.

#### Hazardous components

Chemical name	Synonyms	CAS-No.	Concentration (% w/w)
Interchangeable low viscosity base oil (<20,5 cSt @40°C) *		Not Assigned	0 - 90

### SECTION 4. FIRST-AID MEASURES

If inhaled : No treatment necessary under normal conditions of use.  
If symptoms persist, obtain medical advice.

In case of skin contact : Remove contaminated clothing. Flush exposed area with water and follow by washing with soap if available.  
If persistent irritation occurs, obtain medical attention.

When using high pressure equipment, injection of product under the skin can occur. If high pressure injuries occur, the casualty should be sent immediately to a hospital. Do not wait for symptoms to develop.  
Obtain medical attention even in the absence of apparent wounds.

In case of eye contact : Flush eye with copious quantities of water.  
Remove contact lenses, if present and easy to do. Continue rinsing.  
If persistent irritation occurs, obtain medical attention.

# SAFETY DATA SHEET

According to OSHA Hazard Communication Standard, 29 CFR 1910.1200

## Shell Tellus S2 MX 46

Version 1.1      Revision Date: 04/30/2018      SDS Number: 800010026152      Print Date: 05/01/2018  
Date of last issue: 04/11/2016

- 
- If swallowed : In general no treatment is necessary unless large quantities are swallowed, however, get medical advice.
- Most important symptoms and effects, both acute and delayed : Oil acne/folliculitis signs and symptoms may include formation of black pustules and spots on the skin of exposed areas. Ingestion may result in nausea, vomiting and/or diarrhoea. Local necrosis is evidenced by delayed onset of pain and tissue damage a few hours following injection.
- Protection of first-aiders : When administering first aid, ensure that you are wearing the appropriate personal protective equipment according to the incident, injury and surroundings.
- Indication of any immediate medical attention and special treatment needed : Treat symptomatically.

High pressure injection injuries require prompt surgical intervention and possibly steroid therapy, to minimise tissue damage and loss of function. Because entry wounds are small and do not reflect the seriousness of the underlying damage, surgical exploration to determine the extent of involvement may be necessary. Local anaesthetics or hot soaks should be avoided because they can contribute to swelling, vasospasm and ischaemia. Prompt surgical decompression, debridement and evacuation of foreign material should be performed under general anaesthetics, and wide exploration is essential.

---

### SECTION 5. FIRE-FIGHTING MEASURES

- Suitable extinguishing media : Foam, water spray or fog. Dry chemical powder, carbon dioxide, sand or earth may be used for small fires only.
- Unsuitable extinguishing media : Do not use water in a jet.
- Specific hazards during fire-fighting : Hazardous combustion products may include:  
A complex mixture of airborne solid and liquid particulates and gases (smoke).  
Carbon monoxide may be evolved if incomplete combustion occurs.  
Unidentified organic and inorganic compounds.
- Specific extinguishing methods : Use extinguishing measures that are appropriate to local circumstances and the surrounding environment.
- Special protective equipment for firefighters : Proper protective equipment including chemical resistant gloves are to be worn; chemical resistant suit is indicated if large contact with spilled product is expected. Self-Contained Breathing Apparatus must be worn when approaching a fire in a confined space. Select fire fighter's clothing approved to

# SAFETY DATA SHEET

According to OSHA Hazard Communication Standard, 29 CFR 1910.1200

## Shell Tellus S2 MX 46

Version	Revision Date:	SDS Number:	Print Date: 05/01/2018
1.1	04/30/2018	800010026152	Date of last issue: 04/11/2016

---

relevant Standards (e.g. Europe: EN469).

---

### SECTION 6. ACCIDENTAL RELEASE MEASURES

- Personal precautions, protective equipment and emergency procedures : Avoid contact with skin and eyes.
- Environmental precautions : Use appropriate containment to avoid environmental contamination. Prevent from spreading or entering drains, ditches or rivers by using sand, earth, or other appropriate barriers.
- Local authorities should be advised if significant spillages cannot be contained.
- Methods and materials for containment and cleaning up : Slippery when spilt. Avoid accidents, clean up immediately. Prevent from spreading by making a barrier with sand, earth or other containment material. Reclaim liquid directly or in an absorbent. Soak up residue with an absorbent such as clay, sand or other suitable material and dispose of properly.
- Additional advice : For guidance on selection of personal protective equipment see Chapter 8 of this Safety Data Sheet. For guidance on disposal of spilled material see Chapter 13 of this Safety Data Sheet.

---

### SECTION 7. HANDLING AND STORAGE

- Technical measures : Use local exhaust ventilation if there is risk of inhalation of vapours, mists or aerosols. Use the information in this data sheet as input to a risk assessment of local circumstances to help determine appropriate controls for safe handling, storage and disposal of this material.
- Advice on safe handling : Avoid prolonged or repeated contact with skin. Avoid inhaling vapour and/or mists. When handling product in drums, safety footwear should be worn and proper handling equipment should be used. Properly dispose of any contaminated rags or cleaning materials in order to prevent fires.
- Avoidance of contact : Strong oxidising agents.
- Product Transfer : This material has the potential to be a static accumulator. Proper grounding and bonding procedures should be used during all bulk transfer operations.
- Further information on storage : Keep container tightly closed and in a cool, well-ventilated

# SAFETY DATA SHEET

According to OSHA Hazard Communication Standard, 29 CFR 1910.1200

## Shell Tellus S2 MX 46

Version 1.1      Revision Date: 04/30/2018      SDS Number: 800010026152      Print Date: 05/01/2018  
Date of last issue: 04/11/2016

age stability      place.  
Use properly labeled and closable containers.  
Store at ambient temperature.

Packaging material      :    Suitable material: For containers or container linings, use mild steel or high density polyethylene.  
Unsuitable material: PVC.

Container Advice      :    Polyethylene containers should not be exposed to high temperatures because of possible risk of distortion.

### SECTION 8. EXPOSURE CONTROLS AND PERSONAL PROTECTION

#### Components with workplace control parameters

Components	CAS-No.	Value type (Form of exposure)	Control parameters / Permissible concentration	Basis
Oil mist, mineral	Not Assigned	TWA (Mist)	5 mg/m <sup>3</sup>	OSHA Z-1
Oil mist, mineral		TWA (Inhalable fraction)	5 mg/m <sup>3</sup>	ACGIH

#### Biological occupational exposure limits

No biological limit allocated.

#### Monitoring Methods

Monitoring of the concentration of substances in the breathing zone of workers or in the general workplace may be required to confirm compliance with an OEL and adequacy of exposure controls. For some substances biological monitoring may also be appropriate. Validated exposure measurement methods should be applied by a competent person and samples analysed by an accredited laboratory. Examples of sources of recommended exposure measurement methods are given below or contact the supplier. Further national methods may be available.  
National Institute of Occupational Safety and Health (NIOSH), USA: Manual of Analytical Methods <http://www.cdc.gov/niosh/>  
Occupational Safety and Health Administration (OSHA), USA: Sampling and Analytical Methods <http://www.osha.gov/>  
Health and Safety Executive (HSE), UK: Methods for the Determination of Hazardous Substances <http://www.hse.gov.uk/>  
Institut für Arbeitsschutz Deutschen Gesetzlichen Unfallversicherung (IFA), Germany <http://www.dguv.de/inhalt/index.jsp>  
L'Institut National de Recherche et de Sécurité, (INRS), France <http://www.inrs.fr/accueil>

**Engineering measures**      :    The level of protection and types of controls necessary will vary depending upon potential exposure conditions. Select controls based on a risk assessment of local circumstances. Appropriate measures include:  
Adequate ventilation to control airborne concentrations.

Where material is heated, sprayed or mist formed, there is

# SAFETY DATA SHEET

According to OSHA Hazard Communication Standard, 29 CFR 1910.1200

## Shell Tellus S2 MX 46

Version  
1.1

Revision Date:  
04/30/2018

SDS Number:  
800010026152

Print Date: 05/01/2018  
Date of last issue: 04/11/2016

greater potential for airborne concentrations to be generated.

### General Information:

Define procedures for safe handling and maintenance of controls.

Educate and train workers in the hazards and control measures relevant to normal activities associated with this product.

Ensure appropriate selection, testing and maintenance of equipment used to control exposure, e.g. personal protective equipment, local exhaust ventilation.

Drain down system prior to equipment break-in or maintenance.

Retain drain downs in sealed storage pending disposal or subsequent recycle.

Always observe good personal hygiene measures, such as washing hands after handling the material and before eating, drinking, and/or smoking. Routinely wash work clothing and protective equipment to remove contaminants. Discard contaminated clothing and footwear that cannot be cleaned.

Practice good housekeeping.

### Personal protective equipment

Respiratory protection : No respiratory protection is ordinarily required under normal conditions of use.  
In accordance with good industrial hygiene practices, precautions should be taken to avoid breathing of material.  
If engineering controls do not maintain airborne concentrations to a level which is adequate to protect worker health, select respiratory protection equipment suitable for the specific conditions of use and meeting relevant legislation.  
Check with respiratory protective equipment suppliers.  
Where air-filtering respirators are suitable, select an appropriate combination of mask and filter.  
Select a filter suitable for the combination of organic gases and vapours [Type A/Type P boiling point >65°C (149°F)].

Hand protection  
Remarks

: Where hand contact with the product may occur the use of gloves approved to relevant standards (e.g. Europe: EN374, US: F739) made from the following materials may provide suitable chemical protection. PVC, neoprene or nitrile rubber gloves Suitability and durability of a glove is dependent on usage, e.g. frequency and duration of contact, chemical resistance of glove material, dexterity. Always seek advice from glove suppliers. Contaminated gloves should be replaced. Personal hygiene is a key element of effective hand care. Gloves must only be worn on clean hands. After using gloves, hands should be washed and dried thoroughly. Application of a non-perfumed moisturizer is recommended. For continuous contact we recommend gloves with break-through time of more than 240 minutes with preference for >



# SAFETY DATA SHEET

According to OSHA Hazard Communication Standard, 29 CFR 1910.1200

## Shell Tellus S2 MX 46

Version	Revision Date:	SDS Number:	Print Date: 05/01/2018
1.1	04/30/2018	800010026152	Date of last issue: 04/11/2016

480 minutes where suitable gloves can be identified. For short-term/splash protection we recommend the same, but recognize that suitable gloves offering this level of protection may not be available and in this case a lower breakthrough time maybe acceptable so long as appropriate maintenance and replacement regimes are followed. Glove thickness is not a good predictor of glove resistance to a chemical as it is dependent on the exact composition of the glove material. Glove thickness should be typically greater than 0.35 mm depending on the glove make and model.

- Eye protection : If material is handled such that it could be splashed into eyes, protective eyewear is recommended.
- Skin and body protection : Skin protection is not ordinarily required beyond standard work clothes.  
It is good practice to wear chemical resistant gloves.
- Protective measures : Personal protective equipment (PPE) should meet recommended national standards. Check with PPE suppliers.
- Thermal hazards : Not applicable

### Environmental exposure controls

- General advice : Take appropriate measures to fulfill the requirements of relevant environmental protection legislation. Avoid contamination of the environment by following advice given in Chapter 6. If necessary, prevent undissolved material from being discharged to waste water. Waste water should be treated in a municipal or industrial waste water treatment plant before discharge to surface water.  
Local guidelines on emission limits for volatile substances must be observed for the discharge of exhaust air containing vapour.

### SECTION 9. PHYSICAL AND CHEMICAL PROPERTIES

- Appearance : Liquid at room temperature.
- Colour : clear
- Odour : Slight hydrocarbon
- Odour Threshold : Data not available
- pH : Not applicable
- pour point : -30 °C / -22 °F  
Method: ISO 3016
- Initial boiling point and boiling range : > 280 °C / 536 °F  
estimated value(s)

# SAFETY DATA SHEET

According to OSHA Hazard Communication Standard, 29 CFR  
1910.1200

## Shell Tellus S2 MX 46

Version 1.1      Revision Date: 04/30/2018      SDS Number: 800010026152      Print Date: 05/01/2018  
Date of last issue: 04/11/2016

---

Flash point : 230 °C / 446 °F  
Method: ISO 2592

Evaporation rate : Data not available

Flammability (solid, gas) : Data not available

Upper explosion limit / upper flammability limit : Typical 10 %(V)

Lower explosion limit / Lower flammability limit : Typical 1 %(V)

Vapour pressure : < 0.5 Pa (20 °C / 68 °F)  
estimated value(s)

Relative vapour density : > 1  
estimated value(s)

Relative density : 0.856 (15 °C / 59 °F)

Density : 856 kg/m<sup>3</sup> (15.0 °C / 59.0 °F)  
Method: ISO 12185

Solubility(ies)  
Water solubility : negligible  
Solubility in other solvents : Data not available

Partition coefficient: n-octanol/water : log Pow: > 6  
(based on information on similar products)

Auto-ignition temperature : > 320 °C / 608 °F

Decomposition temperature : Data not available

Viscosity  
Viscosity, dynamic : Data not available  
Viscosity, kinematic : 46 mm<sup>2</sup>/s (40.0 °C / 104.0 °F)  
Method: ISO 3104  
6.9 mm<sup>2</sup>/s (100 °C / 212 °F)  
Method: ISO 3104  
580 mm<sup>2</sup>/s (0 °C / 32 °F)

# SAFETY DATA SHEET

According to OSHA Hazard Communication Standard, 29 CFR 1910.1200

## Shell Tellus S2 MX 46

Version 1.1      Revision Date: 04/30/2018      SDS Number: 800010026152      Print Date: 05/01/2018  
Date of last issue: 04/11/2016

---

Method: ISO 3104

Explosive properties : Not classified  
Oxidizing properties : Data not available  
Conductivity : This material is not expected to be a static accumulator.

---

### SECTION 10. STABILITY AND REACTIVITY

Reactivity : The product does not pose any further reactivity hazards in addition to those listed in the following sub-paragraph.  
Chemical stability : Stable.  
Possibility of hazardous reactions : Reacts with strong oxidising agents.  
Conditions to avoid : Extremes of temperature and direct sunlight.  
Incompatible materials : Strong oxidising agents.  
Hazardous decomposition products : No decomposition if stored and applied as directed.

---

### SECTION 11. TOXICOLOGICAL INFORMATION

Basis for assessment : Information given is based on data on the components and the toxicology of similar products. Unless indicated otherwise, the data presented is representative of the product as a whole, rather than for individual component(s).

#### Information on likely routes of exposure

Skin and eye contact are the primary routes of exposure although exposure may occur following accidental ingestion.

#### Acute toxicity

##### Product:

Acute oral toxicity : LD50 (rat): > 5,000 mg/kg  
Remarks: Low toxicity:  
Based on available data, the classification criteria are not met.  
Acute inhalation toxicity : Remarks: Based on available data, the classification criteria are not met.  
Acute dermal toxicity : LD50 (Rabbit): > 5,000 mg/kg  
Remarks: Low toxicity:  
Based on available data, the classification criteria are not met.

# SAFETY DATA SHEET

According to OSHA Hazard Communication Standard, 29 CFR 1910.1200

## Shell Tellus S2 MX 46

Version  
1.1

Revision Date:  
04/30/2018

SDS Number:  
800010026152

Print Date: 05/01/2018  
Date of last issue: 04/11/2016

---

### Skin corrosion/irritation

**Product:**

Remarks: Slightly irritating to skin., Prolonged or repeated skin contact without proper cleaning can clog the pores of the skin resulting in disorders such as oil acne/folliculitis., Based on available data, the classification criteria are not met.

### Serious eye damage/eye irritation

**Product:**

Remarks: Slightly irritating to the eye., Based on available data, the classification criteria are not met.

### Respiratory or skin sensitisation

**Product:**

Remarks: Not a skin sensitiser.  
Based on available data, the classification criteria are not met.

### Germ cell mutagenicity

**Product:**

: Remarks: Non mutagenic, Based on available data, the classification criteria are not met.

### Carcinogenicity

**Product:**

Remarks: Not a carcinogen., Based on available data, the classification criteria are not met.

Remarks: Product contains mineral oils of types shown to be non-carcinogenic in animal skin-painting studies., Highly refined mineral oils are not classified as carcinogenic by the International Agency for Research on Cancer (IARC).

**IARC**

No component of this product present at levels greater than or equal to 0.1% is identified as probable, possible or confirmed human carcinogen by IARC.

**OSHA**

No component of this product present at levels greater than or equal to 0.1% is on OSHA's list of regulated carcinogens.

**NTP**

No component of this product present at levels greater than or equal to 0.1% is identified as a known or anticipated carcinogen by NTP.

### Reproductive toxicity

**Product:**

:

# SAFETY DATA SHEET

According to OSHA Hazard Communication Standard, 29 CFR  
1910.1200

## Shell Tellus S2 MX 46

Version  
1.1

Revision Date:  
04/30/2018

SDS Number:  
800010026152

Print Date: 05/01/2018  
Date of last issue: 04/11/2016

---

Remarks: Not a developmental toxicant., Does not impair fertility., Based on available data, the classification criteria are not met.

### STOT - single exposure

**Product:**

Remarks: Based on available data, the classification criteria are not met.

### STOT - repeated exposure

**Product:**

Remarks: Based on available data, the classification criteria are not met.

### Aspiration toxicity

**Product:**

Not an aspiration hazard.

### Further information

**Product:**

Remarks: Used oils may contain harmful impurities that have accumulated during use. The concentration of such impurities will depend on use and they may present risks to health and the environment on disposal., ALL used oil should be handled with caution and skin contact avoided as far as possible.

Remarks: High pressure injection of product into the skin may lead to local necrosis if the product is not surgically removed.

Remarks: Slightly irritating to respiratory system.

---

## SECTION 12. ECOLOGICAL INFORMATION

Basis for assessment : Ecotoxicological data have not been determined specifically for this product.  
Information given is based on a knowledge of the components and the ecotoxicology of similar products.  
Unless indicated otherwise, the data presented is representative of the product as a whole, rather than for individual component(s).(LL/EL/IL50 expressed as the nominal amount of product required to prepare aqueous test extract).

### Ecotoxicity

**Product:**

Toxicity to fish (Acute toxicity) :

Remarks: LL/EL/IL50 > 100 mg/l  
Practically non toxic:  
Based on available data, the classification criteria are not met.

# SAFETY DATA SHEET

According to OSHA Hazard Communication Standard, 29 CFR 1910.1200

## Shell Tellus S2 MX 46

Version 1.1      Revision Date: 04/30/2018      SDS Number: 800010026152      Print Date: 05/01/2018  
Date of last issue: 04/11/2016

---

Toxicity to daphnia and other aquatic invertebrates (Acute toxicity) :  
Remarks: LL/EL/IL50 > 100 mg/l  
Practically non toxic:  
Based on available data, the classification criteria are not met.

Toxicity to algae (Acute toxicity) :  
Remarks: LL/EL/IL50 > 100 mg/l  
Practically non toxic:  
Based on available data, the classification criteria are not met.

Toxicity to fish (Chronic toxicity) :  
Remarks: Data not available

Toxicity to daphnia and other aquatic invertebrates (Chronic toxicity) :  
Remarks: Data not available

Toxicity to microorganisms (Acute toxicity) :  
Remarks: Data not available

### Persistence and degradability

#### Product:

Biodegradability :  
Remarks: Not readily biodegradable.  
Major constituents are inherently biodegradable, but contains components that may persist in the environment.

### Bioaccumulative potential

#### Product:

Bioaccumulation :  
Remarks: Contains components with the potential to bioaccumulate.

### Mobility in soil

#### Product:

Mobility :  
Remarks: Liquid under most environmental conditions.  
If it enters soil, it will adsorb to soil particles and will not be mobile.

Remarks: Floats on water.

### Other adverse effects

#### Product:

Additional ecological information :  
Does not have ozone depletion potential, photochemical ozone creation potential or global warming potential.  
Product is a mixture of non-volatile components, which will not be released to air in any significant quantities under normal conditions of use.

# SAFETY DATA SHEET

According to OSHA Hazard Communication Standard, 29 CFR 1910.1200

## Shell Tellus S2 MX 46

Version  
1.1

Revision Date:  
04/30/2018

SDS Number:  
800010026152

Print Date: 05/01/2018  
Date of last issue: 04/11/2016

Poorly soluble mixture.  
Causes physical fouling of aquatic organisms.

Mineral oil does not cause chronic toxicity to aquatic organisms at concentrations less than 1 mg/l.

---

### SECTION 13. DISPOSAL CONSIDERATIONS

#### Disposal methods

Waste from residues : Recover or recycle if possible.  
It is the responsibility of the waste generator to determine the toxicity and physical properties of the material generated to determine the proper waste classification and disposal methods in compliance with applicable regulations.  
Do not dispose into the environment, in drains or in water courses

Waste product should not be allowed to contaminate soil or ground water, or be disposed of into the environment.  
Waste, spills or used product is dangerous waste.

Contaminated packaging : Dispose in accordance with prevailing regulations, preferably to a recognized collector or contractor. The competence of the collector or contractor should be established beforehand.  
Disposal should be in accordance with applicable regional, national, and local laws and regulations.

#### Local legislation

Remarks : Disposal should be in accordance with applicable regional, national, and local laws and regulations.

---

### SECTION 14. TRANSPORT INFORMATION

#### National Regulations

##### US Department of Transportation Classification (49 CFR Parts 171-180)

Not regulated as a dangerous good

#### International Regulations

##### IATA-DGR

Not regulated as a dangerous good

##### IMDG-Code

Not regulated as a dangerous good

#### Transport in bulk according to Annex II of MARPOL 73/78 and the IBC Code

Not applicable for product as supplied. MARPOL Annex 1 rules apply for bulk shipments by sea.

#### Special precautions for user

# SAFETY DATA SHEET

According to OSHA Hazard Communication Standard, 29 CFR 1910.1200

## Shell Tellus S2 MX 46

Version 1.1      Revision Date: 04/30/2018      SDS Number: 800010026152      Print Date: 05/01/2018  
Date of last issue: 04/11/2016

---

Remarks : Special Precautions: Refer to Chapter 7, Handling & Storage, for special precautions which a user needs to be aware of or needs to comply with in connection with transport.

---

### SECTION 15. REGULATORY INFORMATION

#### EPCRA - Emergency Planning and Community Right-to-Know Act

\*: This material does not contain any components with a CERCLA RQ., Shell classifies this material as an "oil" under the CERCLA Petroleum Exclusion, therefore releases to the environment are not reportable under CERCLA.

#### SARA 304 Extremely Hazardous Substances Reportable Quantity

This material does not contain any components with a section 304 EHS RQ.

#### SARA 302 Extremely Hazardous Substances Threshold Planning Quantity

This material does not contain any components with a section 302 EHS TPQ.

**SARA 311/312 Hazards** : No SARA Hazards

**SARA 313** : This material does not contain any chemical components with known CAS numbers that exceed the threshold (De Minimis) reporting levels established by SARA Title III, Section 313.

#### Clean Water Act

This product does not contain any Hazardous Chemicals listed under the U.S. CleanWater Act, Section 311, Table 117.3.

#### US State Regulations

##### Pennsylvania Right To Know

Zinc dialkyldithiophosphate 4259-15-8

##### California Prop. 65

This product does not contain any chemicals known to State of California to cause cancer, birth defects, or any other reproductive harm.

#### The components of this product are reported in the following inventories:

EINECS : All components listed or polymer exempt.

TSCA : All components listed.

DSL : All components listed.

---

### SECTION 16. OTHER INFORMATION

#### Further information



# SAFETY DATA SHEET

According to OSHA Hazard Communication Standard, 29 CFR  
1910.1200

## Shell Tellus S2 MX 46

Version	Revision Date:	SDS Number:	Print Date: 05/01/2018
1.1	04/30/2018	800010026152	Date of last issue: 04/11/2016

NFPA Rating (Health, Fire, Reactivity) 0, 1, 0

### Full text of other abbreviations

ACGIH : USA. ACGIH Threshold Limit Values (TLV)  
OSHA Z-1 : USA. Occupational Exposure Limits (OSHA) - Table Z-1 Limits for Air Contaminants  
ACGIH / TWA : 8-hour, time-weighted average  
OSHA Z-1 / TWA : 8-hour time weighted average  
Abbreviations and Acronyms : The standard abbreviations and acronyms used in this document can be looked up in reference literature (e.g. scientific dictionaries) and/or websites.

ACGIH = American Conference of Governmental Industrial Hygienists  
ADR = European Agreement concerning the International Carriage of Dangerous Goods by Road  
AICS = Australian Inventory of Chemical Substances  
ASTM = American Society for Testing and Materials  
BEL = Biological exposure limits  
BTEX = Benzene, Toluene, Ethylbenzene, Xylenes  
CAS = Chemical Abstracts Service  
CEFIC = European Chemical Industry Council  
CLP = Classification Packaging and Labelling  
COC = Cleveland Open-Cup  
DIN = Deutsches Institut für Normung  
DMEL = Derived Minimal Effect Level  
DNEL = Derived No Effect Level  
DSL = Canada Domestic Substance List  
EC = European Commission  
EC50 = Effective Concentration fifty  
ECETOC = European Center on Ecotoxicology and Toxicology Of Chemicals  
ECHA = European Chemicals Agency  
EINECS = The European Inventory of Existing Commercial Chemical Substances  
EL50 = Effective Loading fifty  
ENCS = Japanese Existing and New Chemical Substances Inventory  
EWC = European Waste Code  
GHS = Globally Harmonised System of Classification and Labelling of Chemicals  
IARC = International Agency for Research on Cancer  
IATA = International Air Transport Association  
IC50 = Inhibitory Concentration fifty  
IL50 = Inhibitory Level fifty  
IMDG = International Maritime Dangerous Goods  
INV = Chinese Chemicals Inventory  
IP346 = Institute of Petroleum test method N° 346 for the determination of polycyclic aromatics DMSO-extractables  
KECI = Korea Existing Chemicals Inventory  
LC50 = Lethal Concentration fifty  
LD50 = Lethal Dose fifty per cent.

# SAFETY DATA SHEET

According to OSHA Hazard Communication Standard, 29 CFR  
1910.1200

## Shell Tellus S2 MX 46

Version	Revision Date:	SDS Number:	Print Date: 05/01/2018
1.1	04/30/2018	800010026152	Date of last issue: 04/11/2016

LL/EL/IL = Lethal Loading/Effective Loading/Inhibitory loading  
LL50 = Lethal Loading fifty  
MARPOL = International Convention for the Prevention of  
Pollution From Ships  
NOEC/NOEL = No Observed Effect Concentration / No Ob-  
served Effect Level  
OE\_HPVS = Occupational Exposure - High Production Volume  
PBT = Persistent, Bioaccumulative and Toxic  
PICCS = Philippine Inventory of Chemicals and Chemical  
Substances  
PNEC = Predicted No Effect Concentration  
REACH = Registration Evaluation And Authorisation Of  
Chemicals  
RID = Regulations Relating to International Carriage of Dan-  
gerous Goods by Rail  
SKIN\_DES = Skin Designation  
STEL = Short term exposure limit  
TRA = Targeted Risk Assessment  
TSCA = US Toxic Substances Control Act  
TWA = Time-Weighted Average  
vPvB = very Persistent and very Bioaccumulative

A vertical bar (|) in the left margin indicates an amendment from the previous version.

Sources of key data used to compile the Safety Data Sheet : The quoted data are from, but not limited to, one or more sources of information (e.g. toxicological data from Shell Health Services, material suppliers' data, CONCAWE, EU IUCLID data base, EC 1272 regulation, etc).

Revision Date : 04/30/2018

The information provided in this Safety Data Sheet is correct to the best of our knowledge, information and belief at the date of its publication. The information given is designed only as a guidance for safe handling, use, processing, storage, transportation, disposal and release and is not to be considered a warranty or quality specification. The information relates only to the specific material designated and may not be valid for such material used in combination with any other materials or in any process, unless specified in the text.

US / EN

## Manufacturer Information

---



- Address: 5506 Thompson Hill Road, Proctor MN 55810
- Phone Number: 218-249-1314
- Email: [info@andinllc.com](mailto:info@andinllc.com)
- Website: [www.andinllc.com](http://www.andinllc.com)
- Patents: US Patent # 10273700, 10619365 - E.U. Patent granted